

## Applications

- Process and general industry
- For water, steam, gas, oil and other media
- Further applications on request

## Operating data

- Maximum allowable pressure 740 psi (51.1 bar)
- Maximum allowable temperature 392°F (200°C)
- Pressure/Temperature rating as per ASME B 16.34 or seat Pressure/temperature rating, whichever is less

## Body Materials

- ASTM A 216 WCB Carbon Steel
- ASTM A 351 CF8 Type 304 Stainless Steel
- ASTM A 351 CF8M Type 316 Stainless Steel

## Ball Materials

- ASTM A 351 CF8 Type 304 Stainless Steel
- ASTM A 351 CF8M Type 316 Stainless Steel

## Seat Material

- PTFE

## Design

- As per BS EN ISO 17292
- Pressure, Temperature rating as per ASME B 16.34
- Testing as per BS EN 12266-1/API 598
- Blowout proof stem
- Antistatic feature

## Variants on Request

- Gear execution
- Pneumatic actuator
- Electric actuator
- Fire safe configuration
- Locking device
- Extended stem for insulation
- Alternate seats in RPTFE, PTFE + Graphite, Peek, Nylon, Acetal Resin

## Remarks :

Other Type Series Booklets

ECOLINE BLC-S 400-800  
ECOLINE BLT-S 150-300  
ECOLINE BLN-S 150-300  
Operating Instructions

## On all enquiries/orders please specify :

1. Valve type
2. ANSI pressure class
3. Size
4. Design pressure
5. Design temperature
6. Operating temperature
7. Differential pressure-shut off
8. Flow medium
9. Material of construction
10. Variants
11. Type Series Booklet no.
12. Valve data sheet (if applicable)

When ordering spares, indicate valve serial number.

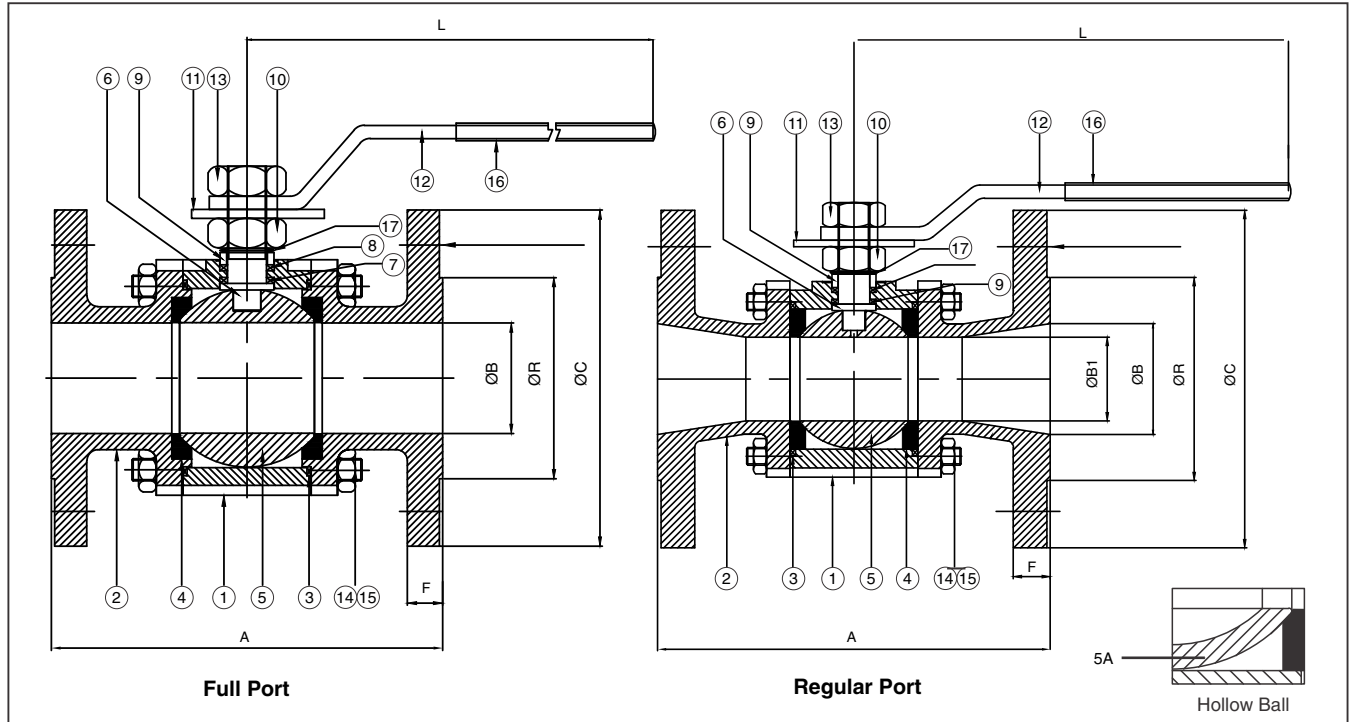

Dimensions in mm

Size	Class - 150								Full Port	Regular Port
	A	ØC	ØR	F	K	N	H	L	ØB	ØB1
DN 15	108	89	35	11.1	60.5	4	16	166	14	11
DN 20	117	98.5	43	11.1	70.0	4	16	194	20	14
DN 25	127	108	51	11.1	79.5	4	16	194	25	20
DN 32	140	117	63.5	13.0	89.0	4	16	235	32	25
DN 40	165	127	73	14.5	98.5	4	16	235	38	32
DN 50	178	152.4	92	15.8	120.5	4	19	278	50	38
DN 65	190	178	105	17.4	140.7	4	19	318	63	50
DN 80	203	191	127	19.1	152.5	4	19	318	75	63
DN 100	229	229	157	24.0	190.5	8	19	318	100	75
DN 150	394	280	216	25.5	241.3	8	22.2	750	150	100

Size	Class - 300								Full Port	Regular Port
	A	ØC	ØR	F	K	N	H	L	ØB	ØB1
DN 15	140	95.2	35	14.3	67.0	4	16	166	14	11
DN 20	152	117.5	43	15.9	82.5	4	19	194	20	14
DN 25	165	124	51	17.5	89.0	4	19	194	25	20
DN 32	178	133	63.5	19.5	98.5	4	19	235	32	25
DN 40	190	156	73	20.6	114.5	4	22	235	38	32
DN 50	216	165	92	22.4	127.0	8	19	278	50	38

### Material

Part No.	Description	Material		
		WCB	Cf8	CF8M
1	Body	WCB	Cf8	CF8M
2	Body Connection	WCB	CF8	CF8M
3	Body Seal	PTFE	PTFE	PTFE
4	Ball Seat	PTFE	PTFE	PTFE
5	♦Ball	CF8M/CF8	CF8	CF8M
6	Stem	SS316/SS304	AISI 304	AISI 316
7	Stem Seal	CFT	CFT	CFT
8	Gland Packing	CFT	CFT	CFT
9	Gland	SS316/SS304	AISI 304	AISI 316
10	Gland Nut	A194-2H	A194-8	A194-8M
11	Lock Plate	MS. Cd. Plated	MS. Cd. Plated	MS. Cd. Plated
12	Lever	MS. Cd. Plated	MS. Cd. Plated	MS. Cd. Plated
13	Lever Nut	A194-2H	A194-2H	A194-2H
14	Body Stud	A193-B7	A193-B8	A193-B8M
15	Body Nut	A194-2H	A194-8	A194-8M
16	Lever Sleeve	PVC	PVC	PVC
17	Disc Spring	Spring Steel	Spring Steel	Spring Steel

### Design Specifications

General valve design	: BS EN ISO 17292
Pressure, temperature rating	: ASME B 16.34 (within the limits of the provided seat material).
Flanged End	: ASME B 16.5
End to end / Face to face dimension	: ASME B 16.10
Testing standard	: BS EN 12266-1 / API 598

### Test Specifications for WCB

Test	Medium	Class - 150		Class - 300	
		kg/cm <sup>2</sup>	psi	kg/cm <sup>2</sup>	psi
Shell	Water	32	456	80	1138
Seat	Water	23*	328*	58*	825*
Seat	Air	6	85	6	85

\* Seat test pressure shall be as per the value indicated in the table above or 1.1 times the rated seat pressure given in the Pressure/Temp. Graph, whichever is less.

♦ Hollow ball for 150# (5A) 40mm to 150mm FP and 50mm to 150mm RP

**Product features to our customer benefit**

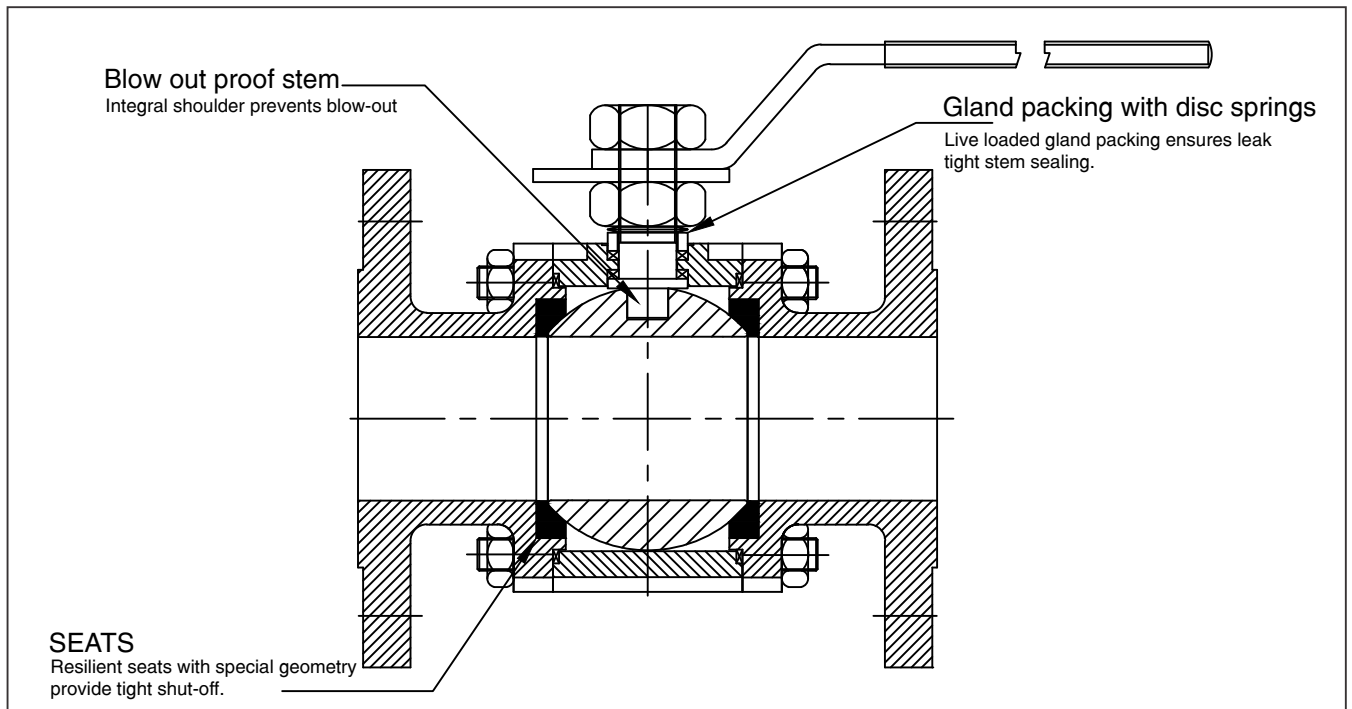

**Blow-out proof stem**

“KSB” valves are of bottom entry stem design. The stem is inserted from inside the body and stem collar sits on the integral land provided in the body. Higher the line pressure, tighter will be the seal. This is a safety features and it does not allow stem to come out and eliminates possible accidents.

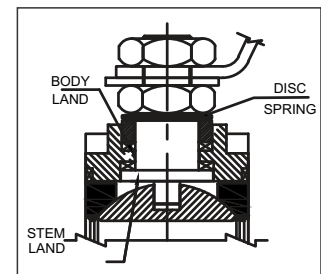

**Stem Seal with Belleville Washer**

Stem packing consist of stem seal and gland packing rings as per design requirement which ensures leak tight stem sealing. Disc springs are pre-compressed and ensure that gland packing load is maintained on the stuffing box. This compensates the varying forces on the sealing gland resulting from changes in pressure and temperature. This also gives excellent thermal conductivity

**Floating Ball**

In closed position, when the line pressure is acting on the upstream side ball, it moves/floats freely towards the down stream side seat giving effective tight sealing. In the open position, the fluid gets trapped in the body cavity and builds up the pressure. Hole provided on the ball prevents this and ensures no damage to the seats.

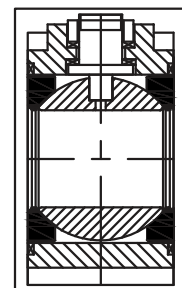

**Antistatic Feature**

During operation, constant rubbings of the ball and PTFE seats may generate static electricity which can lead to fire hazard especially when the service medium is of inflammable nature. A spring and a small ball fitted between ball and stem ensures electrical continuity. For smaller size valves below 40 mm, carbon filled PTFE stem seals provides/meets this continuity.

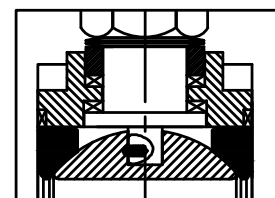

### Pressure Temperature Graphs

**Pressure Temperature Rating : PTFE Seat**

(1) 15 to 100 FP / 10 to 125 RP  
(2) 125 to 150 FP / 150 to 200 RP

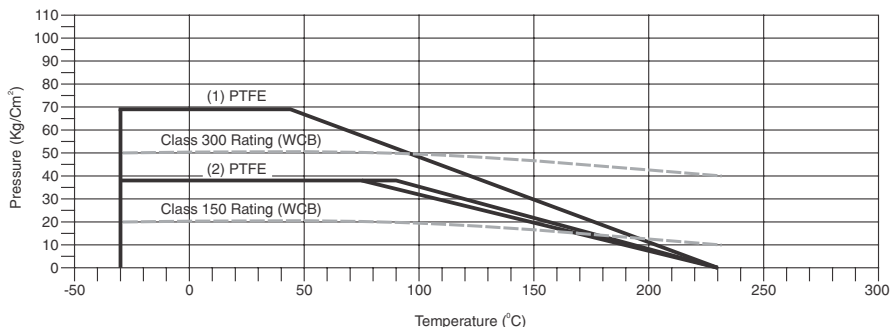

**Pressure Temperature Rating : RPTFE Seat**

(1) 15 to 100 FP / 15 to 125 RP  
(2) 125 to 200 FP / 150 to 200 RP

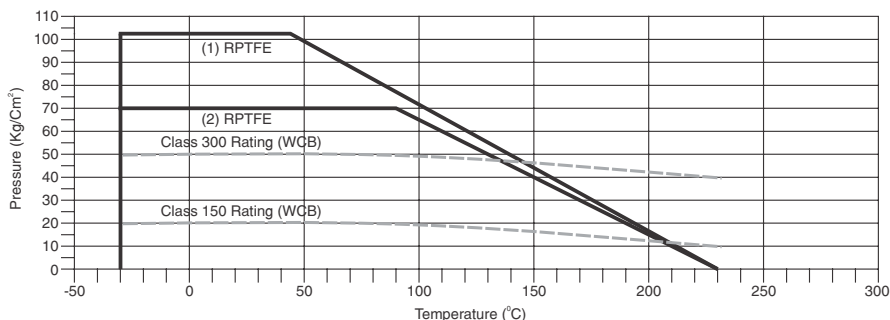

**Pressure Temperature Rating : PEEK Seat**

Note :- For sizes > 50mm, FP, contact KSB

(1) 15 to 25 FP / 15 to 40 RP  
(2) 40 to 50 FP / 50 to 65 RP

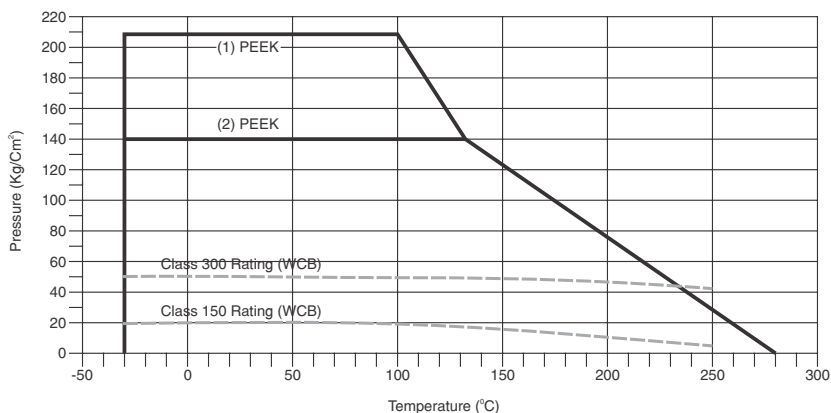

**Pressure Temperature Rating : Nylon / Delrin Seat**

Note :- For sizes > 50mm, FP, contact KSB

(1) 15 to 25 FP / 15 to 40 RP  
(2) 40 to 50 FP / 50 to 65 RP

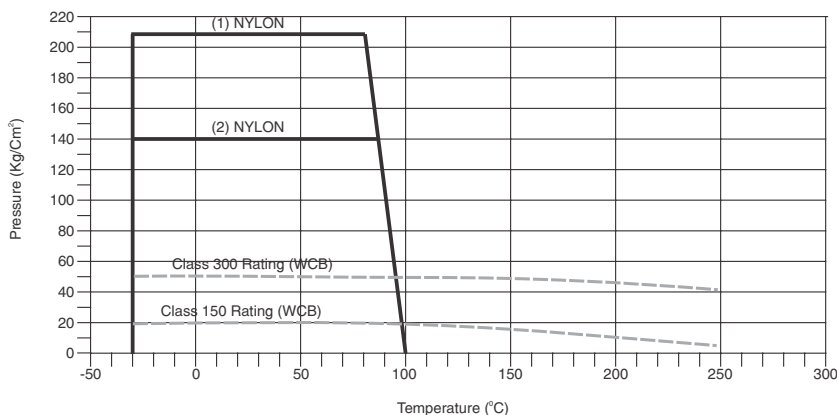

**KSB Limited**

151, Mettupalayam Road, NSN Palayam Post, Coimbatore 641 031. India.  
Tel.: +91 422 2468222 Fax: +91 422 2468232 www.ksbindia.co.in

Technical matter subject to change without prior notice.