

SpeedROC 3F

Surface drill rig for marble, granite, and limestone in the dimension stone industry.

Hole diameter: 28–45 mm (1.1" - 1.8")



Productivity³

The SpeedROC 3F from Epiroc is the latest generation of drill rig for the dimension stone quarrying industry. It features three rock drills which ensures that the rig is both efficient and productive - regardless of whether you are drilling in granite, limestone, marble or sandstone. The SpeedROC 3F sets a new standard for the dimension stone quarrying industry.

In order to reduce weight, the feeds and rails are assembled around a new architecture. This allows the SpeedROC 3F to feature the same, well-proven carrier as the SpeedROC 2F. This helps keep the total cost of ownership at a low level.

All the key components are placed so they are easily accessible for maintenance and service. This helps to reduce downtime to minimum and increase productivity.

+ Main benefits

Three rock drills for high productivity

360° carrier rotation and extensive boom reach means large coverage area

High capacity dust collector for a better working environment



The SpeedROC 3F takes DSI into the third dimension

SpeedROC 3F takes productivity in the dimension stone industry to a new dimension. The rig drills three holes simultaneously which means the SpeedROC 3F can push up productivity to a whole new level.



+ Adding a third dimension to the stone industry

The SpeedROC 3F features three Epiroc COP DS5 hydraulic rock drills. During field tests in a limestone quarry, each COP DS5 drilled an average of 1.5 meters per minute. This equates to a total of two kilometers of drilling over an 8 hour shift.



+ Covering all the angles

Extensive boom coverage, 360° carrier rotation and impressive terrainability allow the SpeedROC 3F to reach almost every part of a quarry. Additionally, four support legs stabilize the rig during drilling so that it can maximize its capabilities.



+ Safety first

The standard Radio Remote Control means the operator is always able to work safe. It also helps to make positioning easier and provides a better overview of operations. Two cameras mounted on the front rail give the operator a good view of the work area if they prefer to work directly from the comfortable cabin. Additionally, a high capacity dust collector helps to keep the work environment clean.



A comprehensive service offering

Even the best equipment needs to be serviced regularly to make sure it sustains peak performance. An Epiroc service solution offers peace of mind, maximizing availability and performance throughout the lifetime of your equipment. We focus on safety, productivity and reliability.

By combining genuine parts and an Epiroc service from our certified technicians, we safeguard your productivity – wherever you are.

Technical specifications

Main Components

- 6 cylinder Doosan DL06 engine Tier 3A/Tier 4 Final
- Three hydraulic rock drills
- Three independent feed systems with rail bar
- Device for asynchronous approach to the ground of the feeds
- Dust Collection System

- Fast system steel retainer
- Full Radio Remote Control (drilling/boom movement/tramming)
- Four independent hydraulic stabilizer legs
- Electronic Control System (ECS)
- Protective Guard according to EN 16228

Hole range (recommended)

Available tophammer rock drill and hole range	Metric	US
COP DS5	28–45 mm	1.1"–1.8"
Starter rod drill steel (hexagonal shape)	19–22 mm	0.75"–0.87"
Length	3.2 m	10.5'

Engine

	Power rating	Fuel consumption
Doosan DL06P Tier 4 Final	139 kW/186 hp (at 1 900 rpm)	16 L/h
Doosan DL 06 Tier 3A	120 kW/161 hp (at 2 000 rpm)	4.2 US gal/h

Hydraulic system

Axial pistons variable displacement main pumps x 2	120 cc
Gear pilot pump	14 cc

Electrical system

Voltage	24 V
Batteries	2x12 V 100 Ah
Alternator	80 A
Additional working lights on drilling unit	2x70 W
Rear camera for tramming	
Tramming lights	

Drilling unit

Oil heating system
Oil cooling system
Proportional control hydraulic valves

Volumes

	Metric	US
Hydraulic oil tank (Tier 3)	118 l	31.2 gal
Hydraulic oil tank (Tier 4)	128 l	33.8 gal
Hydraulic oil, total (Tier 3)	205 l	54.2 gal
Hydraulic oil, total (Tier 4)	207 l	54.7 gal
Compressor oil	6.5 l	1.7 gal
Diesel engine oil	27 l	7.1 gal
Diesel tank (Tier 3)	350 l	92.5 gal
Diesel tank (Tier 4)	292 l	77.1 gal

Selection of options

- Cameras
- Automatic drilling device

Carrier

	Metric	US
Tramming speed, max	9 km/h	5.6 mph
Ground clearance: Tier 3	350 mm	13.8"
Ground clearance: Tier 4	335 mm	13.2"
4WD		
Four hydraulic stabilizer legs		
Tramming angles downward/upward max	15°	Cannot be combined
Tramming angles laterally, max (left, right)	12°	

Feed

Chain feed, hydraulically driven	Metric	US
Feed extension	600 mm	23.6"
Feed force, max	6.5 kN	1461 lbf
Tractive pull, max	6.5 kN	1461 lbf
Total length	4 900 mm	192.9"
Travel length	2 950 mm	116.1"

Control system

Electronically controlled
Radio Remote Control (Tramming/boom movements/drilling)
Drilling low start concerning feed force and percussion
Automatic Drilling device
Advanced anti jamming device

Dust collector DCT 110D

	Metric	US
Filtering area	11 m ²	1118 sq.ft
Suction capacity	320 L/s	678 cfm
Suction hose diameter	60–100 mm	2.4"–3.9"
Number of filters	11	
Auto-cleaning filters		

Compressor

Atlas Copco Ekomak IML 00602	Metric	US
Air flow	42.5 L/s	90 cfm
Maximum pressure	8 bar	116 psi

- Tramming by radio remote
- Protective Guard

Technical specifications

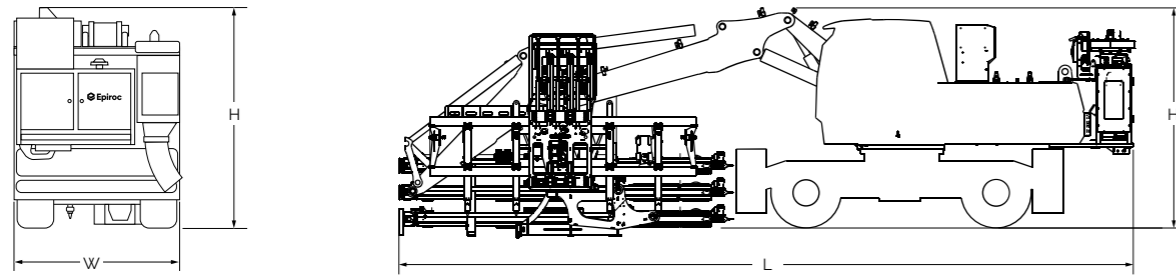

Height and length

	Metric	US
Height (H)	3 300 mm	129.9'
Length (L)	11 000 mm	433.1'
Width (W)	2 550 mm	100.4'

Weight

	Metric	US
Standard unit excluding all options and drill rod	26 700 kg	58 863 lb

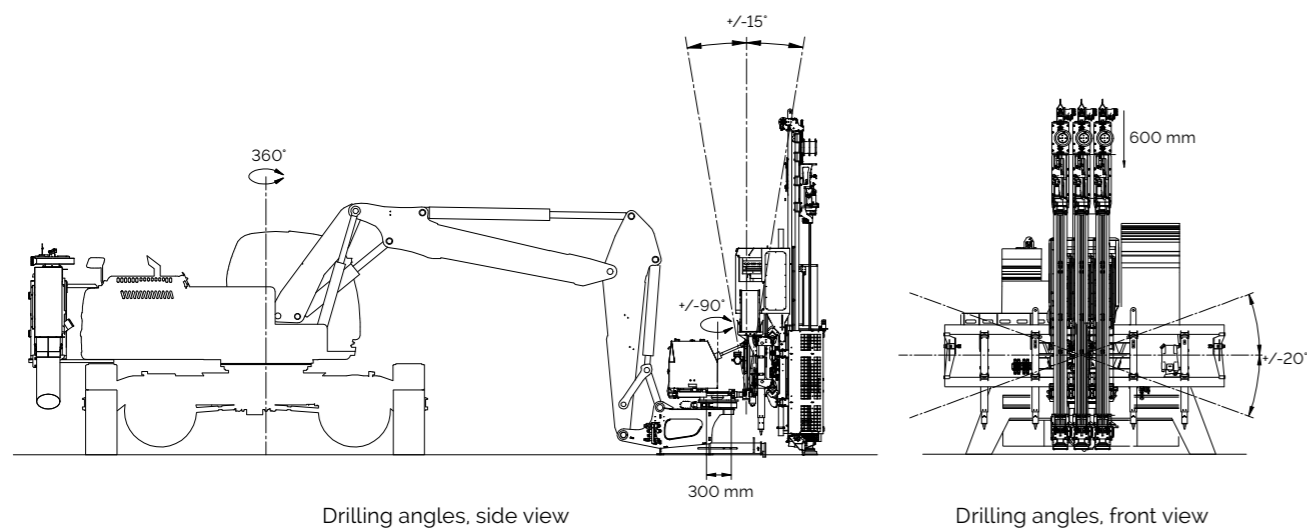

Technical specifications

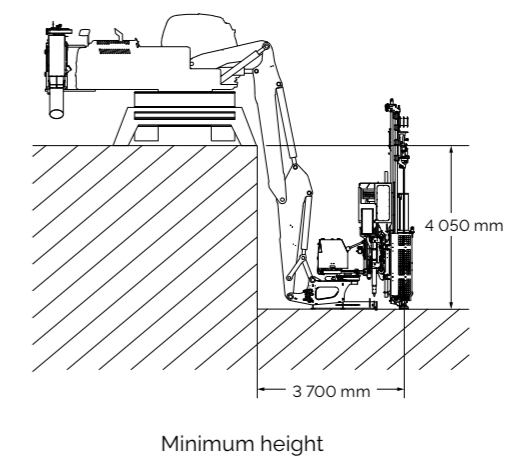
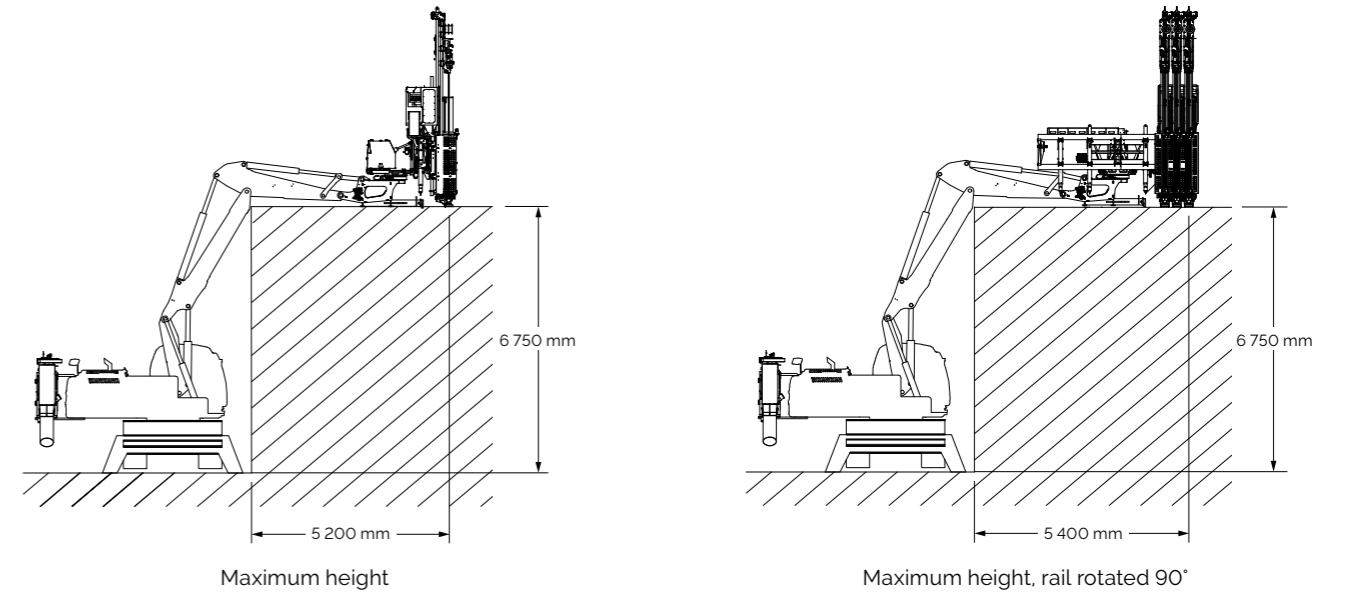
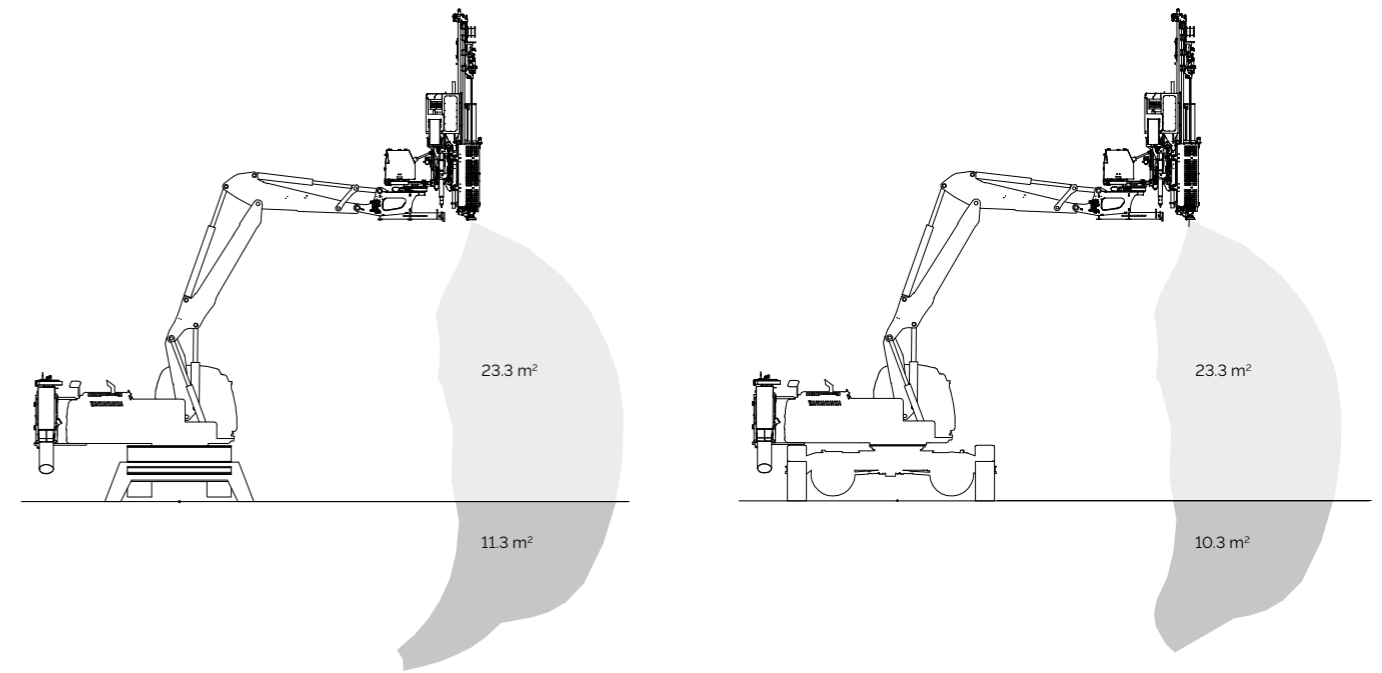

United in performance. Inspired by innovation.

Performance unites us, innovation inspires us, and commitment drives us to keep moving forward. Count on Epiroc to deliver the solutions you need to succeed today and the technology to lead tomorrow.
epiroc.com

