

# SmartROC T45

Surface drill rig for quarrying and construction

Folding boom hole diameter: 89–127 mm (3,5'–5')  
Standard boom hole diameter: 89–140 mm (3,5'–5,5')

 Epiroc





# Smart and precise efficiency

With the SmartROC T45 you're in control. The SmartROC T45 is based on a proven control system which gives consistency in job after job and doesn't, to the same extent, rely on your operator's performance. SmartROC T45 will revolutionize your fuel consumption, improve your availability, and provide you with the documentation you need to be on top of your business. With help from features such as HNS, AutoPos and ROC Manager, you're always on top of your operation.



## ⊕ Main benefits

**Efficiency** with increased capacity and performance while reducing fuel consumption

**Safety and availability** thanks to the new and intuitive design

**Excellence** through precise drilling and consistent operation, resulting in improved blasting results



# Technology that puts you in control

Safety depends on being in control. The SmartROC T45 dramatically reduces the risks of manual errors and human mistakes. With options such as Hole Navigation System (HNS) you have the right information at your fingertips. This greatly improves both efficiency and safety on the bench.



## + Plan your work, then work your plan

The SmartROC T45 relies on automation functionalities to make sure you drill as planned. The automatic feed alignment ensures that you always maintain the desired angle when drilling, which is crucial for optimum blasting results. In addition, the automatic rod adding system makes it easy for the operator, adding rods to the desired depth. The machine drills to the exact desired drilling depth with no mistakes, while the operator supervises until it's time to pick up the rods. Both functions deliver consistent results you can rely on, shift after shift.



## + Cut your fuel costs in half

There are two things the SmartROC T45 never compromises on – fuel efficiency and high productivity. The key to its incredible fuel efficiency is that it only uses the energy it needs for the work at hand. In addition to its standard automatic radiator fan, engine and compressor speed are automatically adjusted depending on operating mode. For example, during tramming or when the rig is not working, the compressor puts no load on the engine and thus reduces engine speed. Further, the airflow and dust collector speed can be adjusted as needed by the operator.



## + Efficiency with environmental care

Epiroc's commitment to the environment is evident in everything we do. We want to maximize your productivity and save you money, at the same time as we leave as few footprints as possible on the environment. That's why the SmartROC T45 is the most energy efficient rig in its class. Its hydraulic system uses significantly less oil, compared to other rigs, with a hydraulic tank that is 1/3 the standard size for its class. This means you can use biological oil with approximately the same cost as regular oil, and you don't have to worry about taking care of spillage.

## A comprehensive service offering

Even the best equipment needs to be serviced regularly to make sure it sustains peak performance. An Epiroc service solution offers peace of mind, maximizing availability and performance throughout the lifetime of your equipment. We focus on safety, productivity and reliability.

By combining genuine parts and an Epiroc service from our certified technicians, we safeguard your productivity – wherever you are.

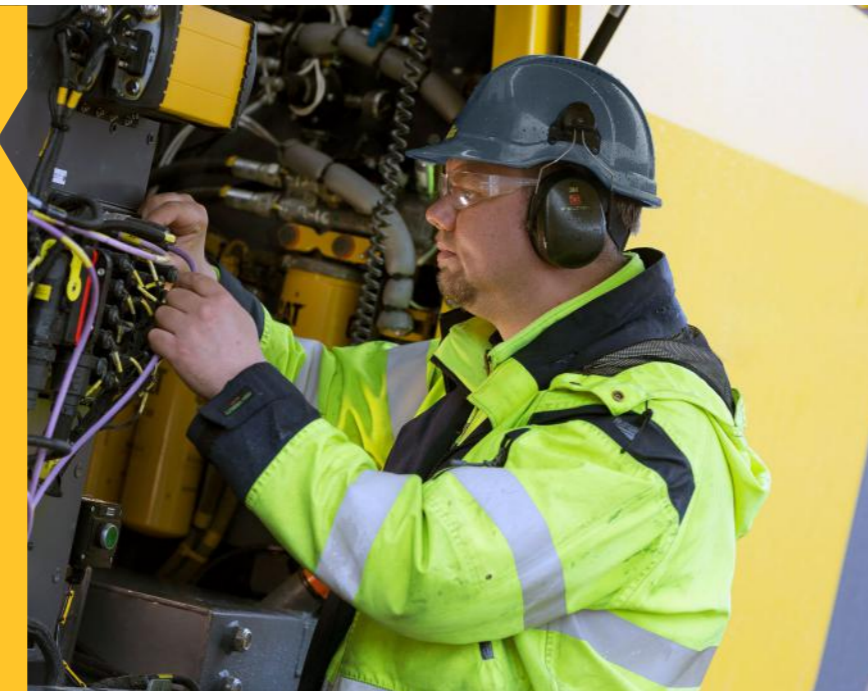

## Technical specifications

### Main Components

- Crawler type two speed undercarriage with track oscillation system
- Caterpillar turbo charged diesel engine
- Epiroc screw type compressor
- Dust pre separator
- Combined warning sound and warning light
- Standard boom system/folding boom system
- Automatic cooler fan control
- Air flow switch
- Rock drill lubrication system
- COP Logic
- Toe-hole drilling system
- Carousel type rod handling system
- Hydraulic double drill rod support with movable dust collector hood
- Double hose drum
- Dust collection system
- AutoPos
- Automatic rod adding
- Operator's cabin, ROPS and FOPS approved

### Hole range (recommended)

	Threads	Metric	US
Standard boom	T51, T60	Ø 89-140 mm	Ø 3.5'-5.5'
Folding boom	T45, T51	Ø 89-127 mm	Ø 3.5'-5'
<b>Rods and length</b>			
Standard boom. Hydraulic rod handling system for max hole length, with 7x4.2 m (14') extensions rods and a 6.1 m (20') starter rod	T51, T60	35 m	115'
Standard boom LF. Hydraulic rod handling system for max hole length, with 5x6.10 m (20') extensions rods and a 7.3 m (24') starter rod	T51, T60	36 m	118'
Folding boom. Hydraulic rod handling system for max hole length, with 7x3.6 m (12') extensions rods and a 4.2 m (14') starter rod	T45, T51	29 m	95'

### Hydraulic rock drill

Rock drill	Boom	Impact power		Hydraulic pressure, max		Impact rate, max	Torque, max		Weight approx	
COP SC25-HE	Folding boom	25 kW	33.5 hp	200 bar	2 900 psi	44 Hz/55 Hz	1 550 Nm	1 143 lbf/ft	195 kg	430 lb
COP SC25X-HE							1 970 Nm	1 453 lbf/ft	249 kg	549 lb
COP 3060	Standard boom	30 kW	41 hp	240 bar	3 481 psi	50 Hz	2 450 Nm	1 807 lbf/ft	315 kg	694 lb
COP 3060EX									355 kg	783 lb

### Feed with standard boom

Hydraulic chain driven aluminum feed with hose guide and double drill rod support with movable lower guide/dust hood	Metric	US
Feed extension (Long feed)	1 900 mm (1 150 mm)	74.8' (45.3')
Feed rate, max	0.9 m/s	177 ft/min
Feed force, max	40 kN	8 992 lbf
Tractive pull, max	50 kN	11 240 lbf
Total length (Long feed)	9 500 mm (11 800 mm)	374' (464.5')
Travel length (Long feed)	5 520 mm (7 630 mm)	217.3' (300')

### Feed with folding boom

Hydraulic chain driven rod feed with hose guide and double drill rod support with moveable lower guide/dust hood	Metric	US
Feed extension	1 150 mm	45.3'
Feed rate, max	0.9 m/s	177 ft/min
Feed force, max	20 kN	4 496 lbf
Tractive pull, max	30 kN	6 744 lbf
Total length	7 700 mm	303'
Travel length	4 610 mm	181.5'

### Engine

Caterpillar turbo charged diesel engine	
CAT C9.3 Tier 4 Final/Stage 5 (EU/US cert.)	250 kW/340 hp (at 1 900 rpm)
CAT C9 Tier 3/Stage IIIA	242 kW/325 hp (at 1 900 rpm)

### Compressor

Atlas Copco C146-07, screw type compressor	Metric	US
Working pressure, max	12 bar	174 psi
FAD, at normal working pressure	223 l/s	473 cfm

### Carrier

	Metric	US
Tramming speed	3.4 km/h	2.1 mph
Track oscillation	±10'	±10'
Ground clearance	405 mm	15.9'

### Volumes

	Metric	US
Hydraulic oil tank	100 l	36.4 gal
Hydraulic system, total	240 l	63.4 gal
Compressor oil	52 l	13.7 gal
Diesel engine oil	32 l	8.4 gal
Diesel engine, cooling water	75 l	19.8 gal
Diesel engine fuel tank	400 l	105.7 gal
Traction gear	3 l	0.8 gal
Lubrication tank (ECL)	23 l	6.1 gal

### Dust collector DCT 200

	Metric	US
Filter area	20 m <sup>2</sup>	215 sq.ft
Number of filter elements	20 pcs	20 pcs
Suction capacity at 500 mm wg	540 L/s	1 144 cfm
Suction hose diam	127 mm	5"
Cleaning air pressure, max	7.5 bar	109 psi
Cleaning air consumption	2-4 l/pulse	0.06-0.12 cu.ft./pulse

### Electrical system

Voltage	24 V
Batteries	2 x 12 V, 185 Ah
Alternator	28 V, 105 Ah
Work lights LED type, front	4 x 3 500 Lumen
Work lights LED type, rear	2 x 3 500 Lumen
Work lights LED type, feed	2 x 5 300 Lumen
Warning lamp and reverse buzzer	

### Hydraulic system

Pumps at 1900 rpm	Metric	US
Axial piston pump (1)	160 l/min	42.3 gal/min
Axial piston pump (2)	120 l/min	31.7 gal/min
Axial piston pump (3)	40 l/min	10.6 gal/min
Gear pump (4)	40 l/min	10.6 gal/min
Gear pump (5)	40 l/min	10.6 gal/min
Hydraulic oil cooler Max ambient temperature	50°C	122°F
Return & drainage filters (filtration rate)	10 µm absolute	

# Technical specifications

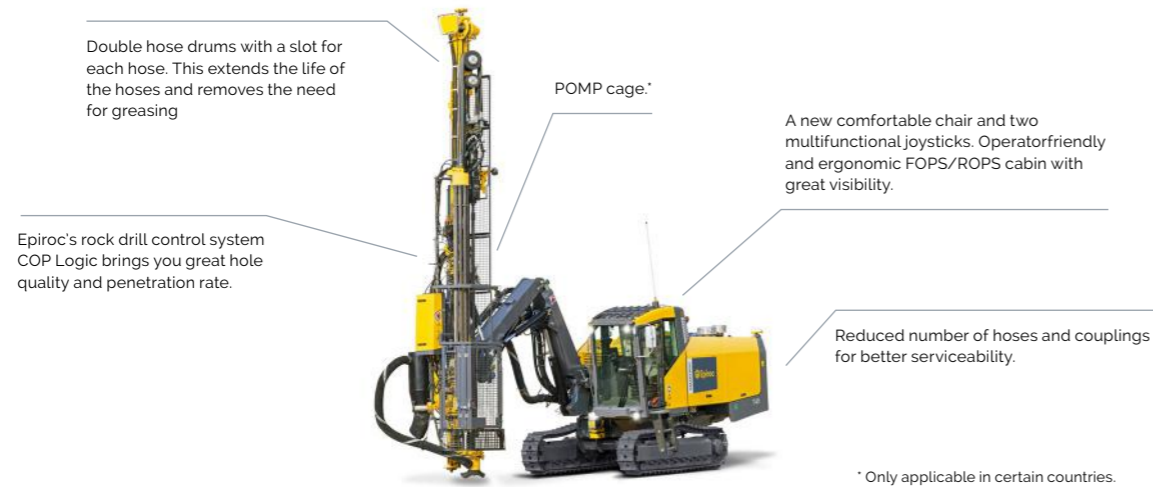

## Cabin

- Air conditioning
- FOPS and ROPS approved with rubber vibration dampers
- 2 x wipers with washer
- Clear laminated glass (front and roof windows)
- Clear toughened glass (side and rear windows)
- Fully adjustable operator's seat
- Adjustable foot rest.
- Cabin light
- Rig inclination indicator
- Rear view mirror
- Fire extinguisher, 6 kg (13 lbs) dry chemical type ABE class III type
- Outlet socket, 24 V
- Prepared with speakers for CD-radio or DVD radio
- Combined front mounted platform/tool box
- Electric combined engine/inclination/hole length instrument in main computer display

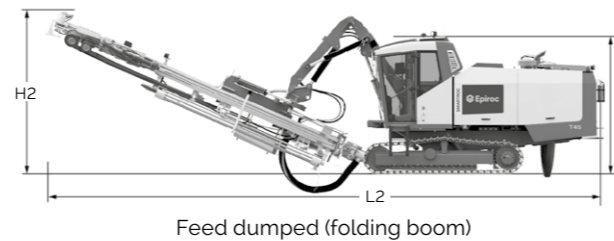
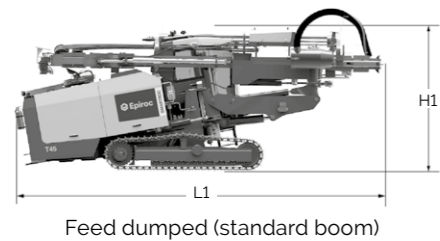
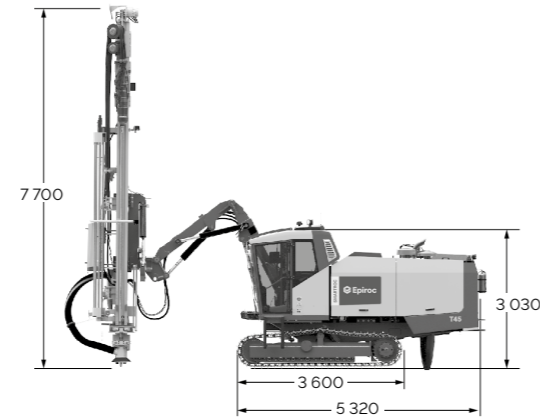
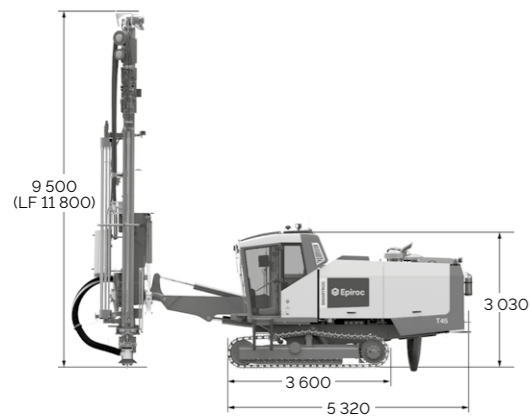

## Transport dimensions

Feed dumped standard boom	Metric	US
Height (H1)	3 300 mm	130.0'
Length (L1)	10 700 mm	421.5'
Height Long Feed (H1)	3 600 mm	142.0'
Length Long Feed (L1)	11 800 mm	464.5'
Feed dumped folding boom		
Height (H2)	3 300 mm	130.0'
Length (L2)	13 300 mm	524.0'

## Weight

Standard unit excluding all options and drill rod	Metric	US
Standard boom	20 100 kg	44 300 lb
Standard boom Long Feed	20 600 kg	45 400 lb
Folding boom	17 700 kg	39 000 lb

# Technical specifications

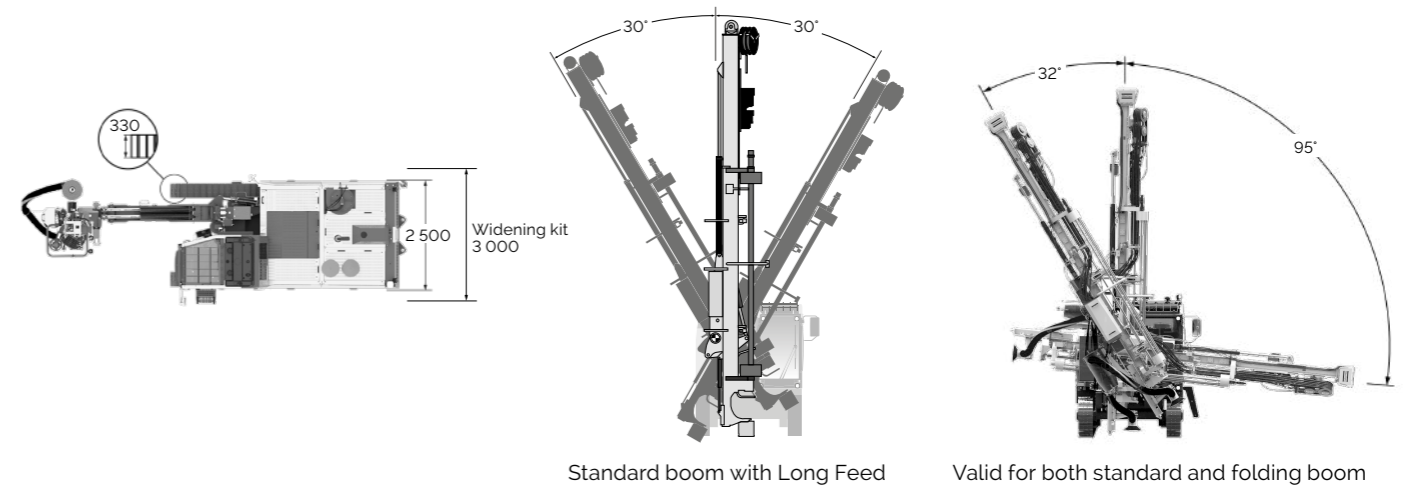
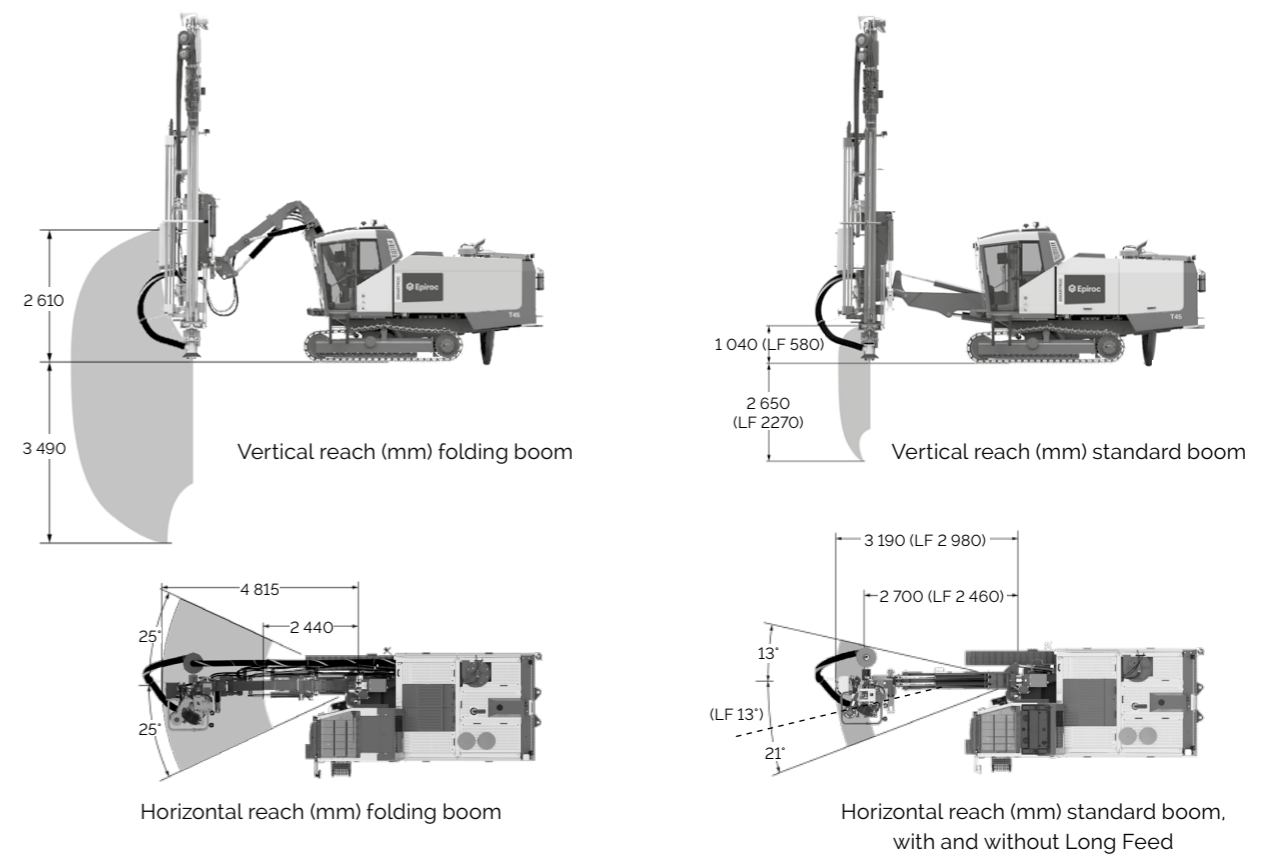

## Selection of options

### Automation & software

- Rig Remote Access (RRA) including/excluding WLAN Module
- Measure While Drilling (MWD)
- ROC Manager

### Cabin

- Combined warning sound and warning light – BEACON type
- Reverse camera with cab mounted display
- Window wiper, right hand window.
- Radio/CD/DVD
- Window panes: Laminated 24 mm clear front, 10 mm roof and 8 mm tinted side – toughend 8 mm rear

### Carrier

- Hydraulic support leg
- Hydraulic winch including wire with towing eye and wire guides

### Feed

- Protective guard, according to EN16228
- Sleeve retainer
- Service winch with jib boom mounted on the feed
- TDS guide tube guides for drill rod support:
  - TDS 64 for 64 mm guide tube
  - TDS 76 for 76 mm guide tube
  - TDS 87 for 87 mm guide tube
- Thread greasing devices

### Hole and inclination systems

- Laser plane receiver for hole depth
- GPS compass aiming unit

### Hole Navigation System (HNS)

- Prepared for Trimble SPS 580/550 and Leica

### Optional equipment not mounted

- Gas charging equipment (for rock drill)
- First 50 hrs service kit for compressor
- Lubrication kit
- Conversion kit T45
- Conversion kit T51
- Conversion kit T60
- RCS service tool-box
- Electrical tool kit

### Parts and Services

- COP Care
- ROC Care

### Water mist system

### Other

- Radio Remote Control (RRC)

# United in performance. Inspired by innovation.

Performance unites us, innovation inspires us, and commitment drives us to keep moving forward. Count on Epiroc to deliver the solutions you need to succeed today and the technology to lead tomorrow.  
**[epiroc.com](https://www.epiroc.com)**

