

# SmartROC T40

Surface drill rigs for quarrying and construction

Hole diameter: 64–127 mm (2.5"–5")





# Master in fuel efficiency

When it comes to fuel efficiency, the SmartROC T40 burns less diesel than any other rig in its class. It's a great performer — even under the toughest drilling conditions.

Built with the operator in mind, an ergonomic user interface makes drilling safer, faster and more effective. Not only is the SmartROC T40 easy to operate and highly productive, but it ensures the lowest cost per cubic meter produced by any comparable rig in its hole range.

The Rig Control System automatically controls the

engine RPM and compressor load to deliver exactly the amount of required power.

Additionally, the entire architecture of the SmartROC T40 is designed to reduce fuel consumption. Vital components are strategically placed and the length of hydraulic hoses is kept to a minimum — this reduces the amount of hydraulic oil needed.

## + Main benefits

- Lowest fuel consumption** in its class
- High productivity** with great hole quality
- Long reach** and perfect balance

# Earn more per cubic meter

SmartROC rigs can be equipped with Epiroc's optional hole navigation system (HNS). This enables drill pattern navigation via GNSS receivers. HNS helps ensure that holes are in the right place, at the correct inclination, and drilled to the required hole length as defined in the drill plan. The result is a decrease in the drill and blast cost per cubic meter produced.



## + Fuel efficiency

The entire system is designed to minimize energy loss. The operator can adjust precisely the flushing air volume and the dust collector fan speed according to need so that both deliver only what is necessary for the best performance. Engine RPM and compressor load are self-adjusting according to demand. Three variable hydraulic pumps help lower engine speed during none-drilling time and tramming. Additionally, an automatic cooler-fan control is standard.



## + Operator in focus

For technology to be of value, it must be easy it is to use. This rig seamlessly integrates advanced technology, ease-of-use and safety. The air-conditioned cabin is FOPS and ROPS approved to protect the operator and is a pleasant environment to work in. The operator has full control over an efficient drilling cycle via two multifunction, joysticks and an icon-based instrument panel. The ergonomically designed controls together with supporting armrests help to reduce the strain on arms and wrists.



## + Improved serviceability

Compared to similar rigs on the market, the SmartROC T40 has 50% fewer hoses and 70% fewer couplings which reduces the risk of leakage. As a result, it only requires a hydraulic tank of 100 liters. The small hydraulic oil tank and the position of the hydraulic valves and electric modules leaves more space for easier access and serviceability. The service interval of the COP rock drills is extended to 800 percussion hours, which means more time to focus on drilling.

## A comprehensive service offering

Even the best equipment needs to be serviced regularly to make sure it sustains peak performance. An Epiroc service solution offers peace of mind, maximizing availability and performance throughout the lifetime of your equipment. We focus on safety, productivity and reliability.

By combining genuine parts and an Epiroc service from our certified technicians, we safeguard your productivity – wherever you are.



## Technical specifications

### Main components

- Track frames with single grouser pads and cleaning holes.
- Hydraulic track oscillation and two speed traction
- Atlas Copco screw type compressor.
- Operator's cabin, FOPS and ROPS approved.
- LED work lights.
- Folding boom system.
- Aluminum profile feed beam.
- Hydraulic cylinder feed system.
- Carousel type rod handling system, 1 + 7 rods.
- Hydraulic rock drill.
- Dust collector (DCT).
- Dust pre separator.
- Double hose drum.
- Adjustable flushing air system.
- Air flow switch.
- Automatic cooler fan control.
- Adjustable dust collector fan speed.
- Double hydraulic drill rod support with movable down support.
- Service lamp inside canopy.
- Rock drill oil collecting system.
- Rubber skirt for Dust collector (DCT).
- COP Logic.

### Hole range (recommended)

	Threads	Metric	US
	T45, T51	Ø 64-127 mm	2.5'-5'
<b>Rods and hole length</b>			
Length with starter rod 4,2 m (14') with 3,6 m (12') extension rods (Standard), Noise Reduction Kit	T45, T51	28 m	91.9'
Length with starter rod 5,5 m (18') with 4,2 m (14') extension rods	T45	33.5 m	109.9'
Length with starter rod 5,5 m (18') with 4,2 m (14') extension rods	T51	29.3 m	96.1'

### Hydraulic Rock drill

Rock drill	Hole diameter	Impact power	Hydraulic pressure, max	Impact rate, max	Torque, max	Weight approx		
COP SC25-HF	Ø 64-89 mm	Ø 2.5"-3.5"	25 kW/33.5 hp	240 bar	3 481 psi	55/71 Hz	189 kg	417 lb
COP SC25X-HF							250 kg	551 lb
COP SC25-HE	Ø 76-127 mm	Ø 3"-5"	25 kW/33.5 hp	200 bar	2 900 psi	44/55 Hz	195 kg	430 lb
COP SC25X-HE							255 kg	562 lb

### Engine

Caterpillar turbo charged diesel engine	
CAT C71 Tier 4 Final/Stage 5 (EU/US cert.)	168 kW/225 hp
CAT C71 Tier 3/stage IIIA	(at 2 200 rpm)

### Compressor

Atlas Copco OIS K-36-C111 GD, screw compressor		
Working pressure, max	10.5 bar	152 psi
FAD, at normal working pressure	153 L/s	325 cfm

### Feed

Hydraulic cylinder feed with hose guide and double drill rod support with movable lower guide/dust hood	Metric	US
Extension	1 400 mm	55.1'
Rate, max	0.92 m/s	184 ft/min
Force, max	20 kN	4 400 lbf
Tractive pull, max	20 kN	4 400 lbf
Total length	7 440 mm	292.9'
Travel length	4 240 mm	166.9'

### Electrical system

Voltage	24 V
Batteries	2 x 12 V, 185 Ah
Alternator (Tier 3)	28 V, 80 Ah
Alternator (Tier 4 Final)	28 V, 105 Ah
Work lights LED type, front	4 x 3 500 lumen
Work lights LED type, rear	2 x 3 500 lumen
Work lights LED type, feed	2 x 5 300 lumen
Warning lamp and reverse buzzer	

### Volumes

	Metric	US
Hydraulic oil tank	100 l	26.4 gal
Hydraulic system, total	160 l	42.3 gal
Compressor oil	22 l	5.8 gal
Diesel engine oil	16 l	4.2 gal
Diesel engine, cooling water	43 l	11.4 gal
Diesel engine fuel tank	370 l	97.7 gal
Traction gear	3 l	0.8 gal
Lubrication tank (ECL)	10 l	2.6 gal
DEF fluid tank (Tier 4 Final only)	24 l	6.3 gal

### Hydraulic system

Pumps at 1800 rpm	Metric	US
Axial piston pump (1)	145 l/min	38.3 gal/min
Gear pump (2)	75 l/min	19.8 gal/min
Gear pump (3)	50 l/min	13.2 gal/min
Gear pump (4)	30 l/min	7.9 gal/min
Gear pump (5)	40 l/min	10.6 gal/min
Hydraulic oil cooler max ambient temp.	50°C	122°F
Return & drainage filters (filtration rate)	10 µm absolute	
Anti-jamming, Feed speed control, Proportional control – feed RPCF, Proportional control impact DPCI		

### Dust collector DCT 110

	Metric	US
Filter area	11 m <sup>2</sup>	118 sq.ft
Number of filter elements	11 pcs	11 pcs
Suction capacity at 500 mm wg	560 L/s	1 200 cfm
Suction hose diam	127 mm	5"
Cleaning air pressure, max	7.5 bar	109 psi
Cleaning air consumption	2-4 l/pulse	0.06-0.12 cu.ft/pulse

### Carrier

	Metric	US
Tramming speed	3.1 km/h	1.5 mph
Track oscillation	±12°	±12°
Ground clearance	455 mm	17.9"

## Technical specifications

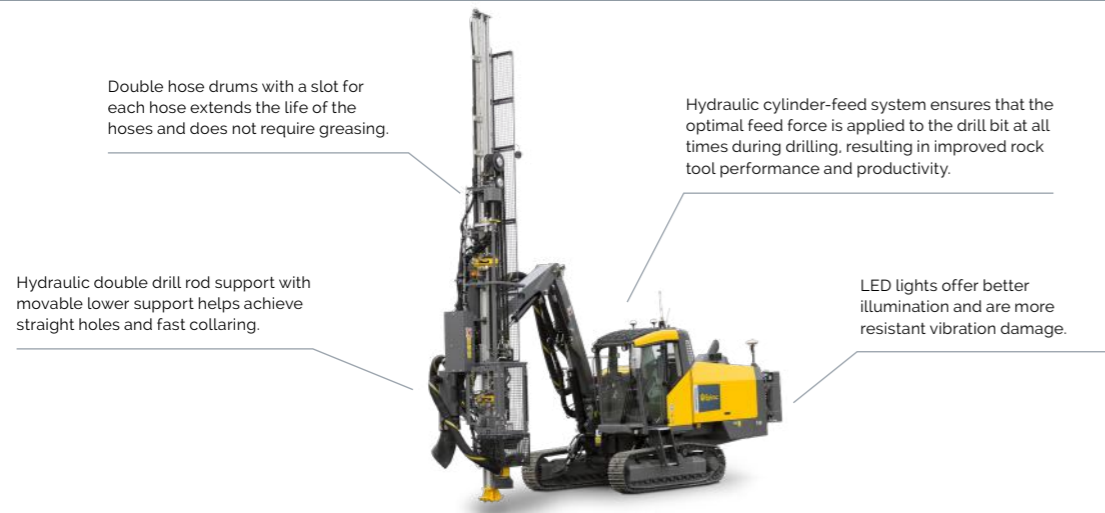

### Cabin

- Air condition.
- ROPS and FOPS approved with rubber vibration dampers.
- 2 x wipers with washer (front window and roof window).
- Clear laminated glass (10 mm front and roof windows).
- Clear laminated glass (8 mm side window).
- Clear toughened glass (8mm rear window).
- Fully adjustable operator's seat.
- Cabin light.
- Rig inclination indicator.
- Rear view mirror.
- Fire extinguisher, 6 kg (13 lbs) dry chemical type ABE class III type.
- Outlet socket, 24 V.
- Cab heating.
- Prepared with speakers for CD-radio or DVD radio.
- Combined front mounted platform/tool box.
- Electric combined engine inclination & hole length instrument in main computer display.
- Electrical heated chair.

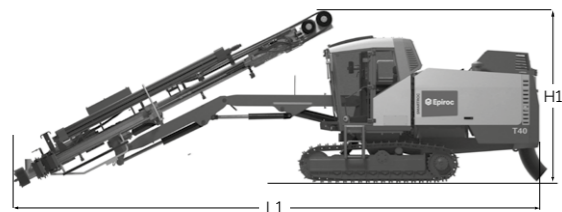
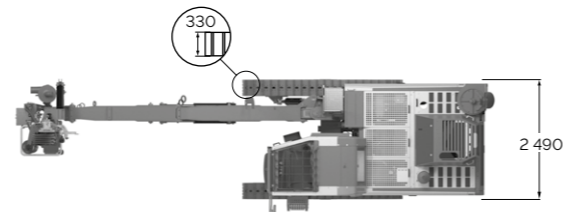
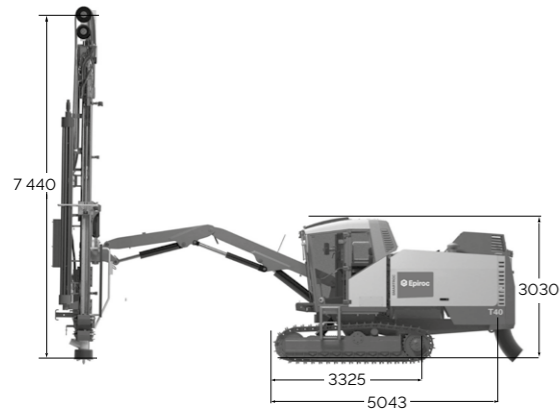

Feed dumped 1

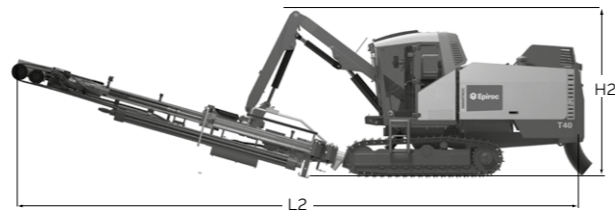

Feed dumped 2

### Transport dimensions

Feed dumped 1	Metric	US
Height (H1)	3 300 mm	129.9'
Length (L1)	11 600 mm	456.7'
Feed dumped 2		
Height (H2)	3 400 mm	133.9'
Length (L2)	11 000 mm	433.1'

### Weight

Standard unit excluding all options and drill rod	Metric	US
Tier 3 engine	15 100 kg	33 290 lb
Tier 4 Final engine	15 300 kg	33 730 lb

## Technical specifications

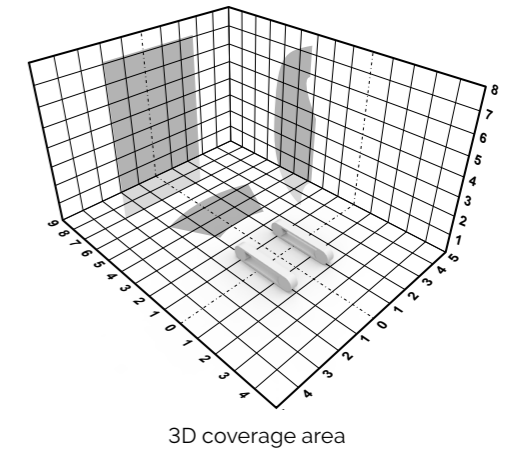
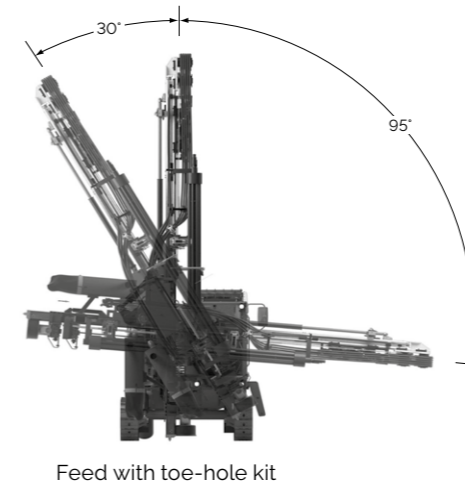
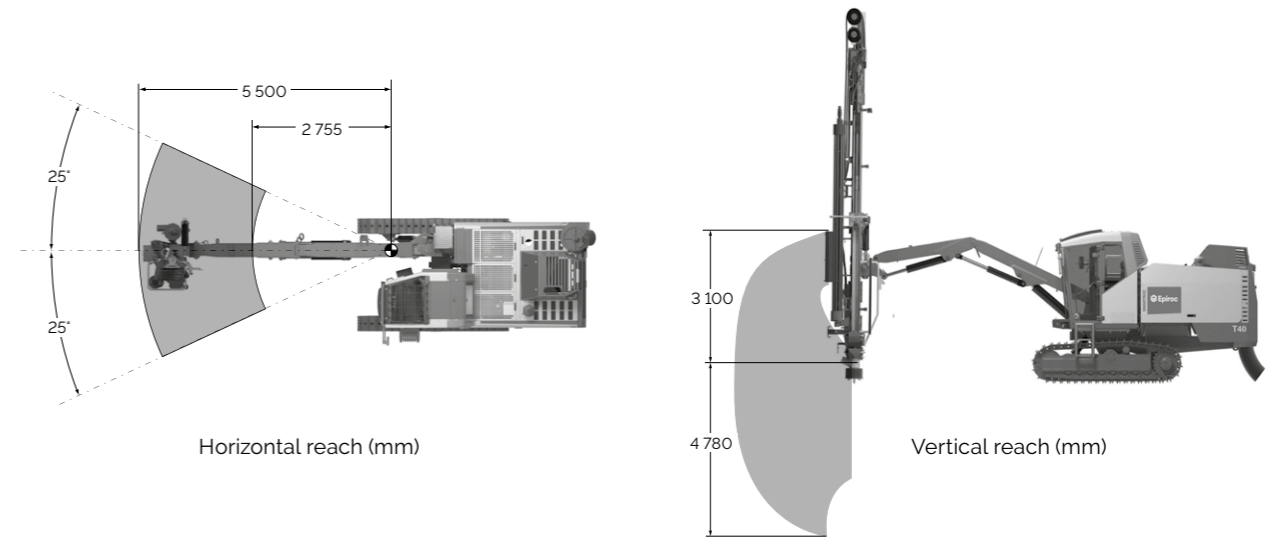

### Selection of options

#### Cabin

- Window panes: Laminated 24 mm clear front, 10 mm roof and 8 mm tinted side – toughened 8 mm rear
- Tinted 10 mm roof window
- Window wiper on right hand window
- Sun shade kit (rear side, rear windows and roof)
- Reverse camera with cab mounted display
- Radio with CD player
- Camera for support leg

#### Carrier

- Hydraulic support leg
- Hydraulic winch including wire with towing eye and wire guides
- Diesel-driven engine heater
- Electric fuel filling system
- Tow hook
- Track chains with triple grouser pads
- LED side lights (points backwards towards the tracks)
- Rubber disc for DCT
- PAR Oil M & S
- Central lubrication system

#### Feed

- Air Anti Freezing System
- Tool box left rear side
- Extra air outlet on front of the carrier
- Protective guard, according to EN16228
- Noise Reduction Kit
- Bigger dowel with big plate to avoid sinking in soft ground
- TDS guide tube guides for drill rod support:
  - TDS 64 for 64 mm guide tube
  - TDS 76 for 76 mm guide tube
  - TDS 87 for 87 mm guide tube
- Support bracket RHS carousel
- Thread greasing devise ECG (with oil)
- Thread greasing device, brush type (with grease)

#### Hole and inclination systems

- Laser plane receiver for hole length
- GPS compass aiming unit
- Automatic feed alignment

#### Water system

Complete water mist system 150 l tank

#### Parts and services

- COP Care
- ROC Care

#### Hole Navigation System (HNS)

- Trimble or Leica receivers radio modem
- 450 or 900 MHZ GSM modem sensors and ROC Manager software

#### Automation & software

- Measure While Drilling (MWD)
- ROC Manager
- Interface for 3 part HNS system

#### Optional equipment not mounted

- Gas charging equipment for rock drill
- First 50 hours service kit for compressor
- Lubrication system
- Conversion kit T45, T51
- Measure While Drilling (MWD)
- RCS service tool-box
- Electrical tool kit

# United in performance. Inspired by innovation.

Performance unites us, innovation inspires us, and commitment drives us to keep moving forward. Count on Epiroc to deliver the solutions you need to succeed today and the technology to lead tomorrow.  
**[epiroc.com](https://www.epiroc.com)**

