

# SmartROC D50

DTH surface drill rig for quarrying and mining

SmartROC D50 hole diameter: 90-130 mm (3.5 - 5.1')



# Versatility, efficiency and intelligence

The SmartROC D50 is a tough, reliable rig that is enhanced with the latest Epiroc automation technology. It has been designed to handle a wide range of demanding jobs with speed and precision.

The SmartROC D50 is controlled via an advanced rig control system displayed on a touch-screen inside the comfortable, air-conditioned FOPS and ROPS-certified cabin. The screen presents everything from drilling parameters to real-time Measure While Drilling data (MWD). The rig control system also features self-diagnostic functions to help track down issues quickly and keep unplanned downtime to a minimum.

This rig is ready to significantly raise quality across your whole operation.

## ⊕ Main benefits

**Low fuel consumption combined with high productivity** due to the intelligent, rig control system and an auto-drill cycle

**Automated and packed with smart features** as standard. Smart options such as BenchREMOTE and Auto Feed Fold further enhance productivity

**A future-proof, secure investment** thanks to updates and options which can be installed in the field

The fully-automated drill cycle reaches the desired hole depth while drill tubes are added and extracted automatically as necessary.



The BenchREMOTE option enables one person to safely control up to three SmartROC rigs at the same time from a horizontal distance of 100 meters. This increases operator productivity dramatically and takes safety to a whole new level.



SmartROC rigs feature a quick and efficient automatic rod handling system. The system includes integrated sensors and a heavy-duty chain which provides a quick, uniform feed rate.



The optional Radio Remote Control allows the operator to step outside the cabin and control a SmartROC D50 from a safe distance when necessary. The integrated display shows all the basic information needed to run the rig.

Semi-automatic feed alignment system ensures that the hole is aligned exactly as desired.

A robust feed with integrated sensors means fewer breakdowns and more reliable rod handling.

The air-conditioned cabin is ROPS and FOPS-approved and mounted on a protective plate.

Smart options such as the Hole Navigation System (HNS) reduces your non-drilling time and improves precision.

CAT C11 (Tier 3) or CAT C13 (Tier 4 Final/Stage 5 technology) turbo-charged diesel engine



Discover more about the SmartROC D50

# The smart way to increase productivity

The SmartROC D50 possess both intelligence and power. It excels in production drilling and auxiliary applications such as toe-hole drilling. This smart, rugged machine features automatic rod handling, a unique aluminium feed and an intelligent control system.



## + A rig you can rely on – shift after shift

SmartROC rigs from Epiroc work consistently and effectively even in the most demanding conditions. Air capacity is the most important factor affecting down-the-hole performance. The engine and compressor in a SmartROC drill rig are controlled by an intelligent system which delivers more free air and force down to the hammer just when you need it most. Smarter drilling means less wasted air, greatly reduced fuel costs and less wear on parts.



## + Sophisticated and versatile yet easy to maintain

With the SmartROC D50, an operator is not just limited to production drilling. The feed can be positioned horizontally which makes it possible to perform toe-hole drilling and create de-watering holes. It also makes it easier and safer to add or remove tubes from the carousel and perform maintenance. The SmartROC D50 also uses 300 liters less hydraulic oil than previous versions and features fewer hoses and pumps. This helps to further reduce costs and makes servicing easier, whilst increasing sustainability and reducing the environmental impact of the rig.



## + Reduce your costs

Epiroc's Hole Navigation System is a smart option which enables a faster set-up for each hole – you can get right down to effective, precise drilling in all weather conditions. A SmartROC rig reduces production costs by optimizing drilling and blasting. Fragmentation is improved and a smaller amount of explosives are required. It also removes the need for manually marking holes on the bench which both saves time and increases safety by removing people from a potentially dangerous area.



## A comprehensive service offering

Even the best equipment needs to be serviced regularly to make sure it sustains peak performance. An Epiroc service solution offers peace of mind, maximizing availability and performance throughout the lifetime of your equipment. We focus on safety, productivity and reliability.

By combining genuine parts and an Epiroc service from our certified technicians, we safeguard your productivity – wherever you are.

### Main components

- Crawler type two speed undercarriage with track oscillation system
- CAT C11 (Tier 3) or CAT C13 (Tier 4 Final/Stage V technology) turbo-charged diesel engine
- Atlas Copco screw-type high-pressure compressors
- ROPS and FOPS-approved operator cabin with rubber vibration dampers
- Aluminum profile feed beam
- Single-section boom system
- Toe hole drilling capability
- Carousel type: RHS 102
- Break-out table with pressure regulating kit
- Hydraulic operated rotary head
- Electric pump for filling hydraulic oil

### Hammer size, hole range & length (recommended)

		Metric	US
SmartROC D50	QLX 35, COP 44 Gold	90-130 mm	3.63-5.1'
<b>Hydraulic tube handling system for max hole length, with 5 m (16.4') tubes – standard feed</b>			
SmartROC D50	Ø 76-102 mm (3'- 4') drill rods	45 m	148'
<b>Single pass drilling, max hole length</b>			
SmartROC D50		5.4 m	18'

### Rotary head

	Connection thread	Max rpm	Max torque, drilling		Suitable for DTH-hammer
			Metric	US	
DHR6 H 45	API 2 3/8" REG, box	137	1 839 Nm	1 356 lbf	QLX 35, COP 44 Gold. (COP 54 Gold)
DHR6 H 56	API 3 1/2" REG, box	107	2 353 Nm	1 735 lbf	COP 54 Gold

### Engine

SmartROC D50	Metric	US
CAT C11 turbo-charged diesel engine, Tier 3/EU Stage IIIA - power rating at 1800 rpm	287 kW	385 HP
CAT C13 turbo-charged diesel engine, Tier 4 Final /EU Stage 5 (multi-certified for US and EU markets) - power rating at 1 800 rpm	287 kW	385 HP

### Electrical system

Voltage	24 V
Batteries	2 x 12 V, 235 Ah
Alternator	28 V, 95 Ah
Work lights, front	4 x 4 200 Lumen
Work lights, rear	2 x 4 200 Lumen
Work lights, feed	2 x 4 200 Lumen
Warning lamp and reverse buzzer	

### Compressor

Atlas Copco XRX 10 two-stage screw type compressor

SmartROC D50	Metric	US
Working pressure, max	25 bar	363 psi
FAD at 25 bar	295 l/s	625 cfm

### Hydraulic system

Hydraulic oil cooler	Metric	US
Max ambient temperature	55°C	131°F
<b>Pumps</b>		
Axial piston pump (1)	225 l/min	59.4 gal/min
Axial piston pump (2)	160 l/min	42.3 gal/min
Axial piston pump (3)	63 l/min	16.6 gal/min
Gear pump (4)	41 l/min	10.8 gal/min
Gear pump (5)	41 l/min	10.8 gal/min
<b>Return and drainage filters (2 x 3 filters)</b>		
Filtration rate	10 µm absolute	

### Carrier

	Metric	US
Tramming speed, max	3.2 km/h	2.0 mph
Traction force, max	138 kN	31 020 lbf
Ground clearance	405 mm	16"
Track oscillation	+10'	

### Volumes

	Metric	US		Metric	US
Hydraulic oil tank	120 l	31.7 gal	Diesel engine, cooling water, Tier 4	110 l	29 gal
Hydraulic system, total	270 l	71.3 gal	Diesel engine fuel tank	975 l	258 gal
Compressor oil	63 l	12 gal	Traction gear	3 l	0.8 gal
Diesel engine oil	44 l	11.6 gal	Lubrication tank (HECL + ECL)	20 l	5.3 gal
Diesel engine, cooling water, Tier 3	65 l	17 gal	DEF fluid tank (Tier 4 final only)	34 l	9 gal

### Aluminum feed

Aluminum profile feed with hose guide and double drill tube support with break-out table and movable lower guide/dust hood	Metric	US
Feed rate, max	0.9 m/s	177 ft/min
Feed force, max	40 kN	8 992 lbf
Tractive pull, max	50 kN	11 240 lbf
Feed motor size	2099 cc	0.6 US gal
Chain size	45 mm	1.8"
Feed extension	1 150 mm	45.3'
Travel length	5 400 mm	212.6'
Total length	9 400 mm	370'

### Dust collector

SmartROC D50 - DCT 200	Metric	US
Filter area	20 m²	215 sq.ft
Suction capacity at 500 mm wg	850 l/s	3 002 cfm
Suction hose diameter	152 mm	6"
Cleaning air pressure, max	8 bar	116 psi
Cleaning air consumption	2-4 l/pulse	0.06-0.12 cfm/pulse
Number of filter elements	20 pcs	

**Cabin**

- ROPS and FOPS approved with rubber vibration dampers
- 2 x wipers with washer
- Clear laminated glass (front and roof windows)
- Clear toughened glass (side and rear windows)
- Fully adjustable, electrically heated operator seat
- Foot rest
- Cabin light
- Air conditioning/heating
- Rig inclination indicator
- Rear view mirror
- 24 V outlet socket
- Prepared for CD radio
- Electric combined engine/inclination hole depth instrument

**A selection of options**

**Carrier**

- Wide body kit
- Hydraulic support leg
- Protection hand rails on top of canopy
- Extra LED worklight package
- Heavy duty air intake filters for engine and compressor
- Combined warning sound and beacon
- Manual or automatic Ansul Checkfire 210 fire extinguisher system
- Electric fuel filling pump
- Fast fuel-filling system
- Diesel-driven engine pre-heater
- Insulated and heated compressor regulation system
- Arctic Fox -40°C cold start
- Battery sliding tray

**Water mist system**

- Water mist system, pump, one or two 400 l water tanks
- Arctic-ready water mist system, pump, one or two 400 l water tanks

**Cabin**

- 6 kg dry chemical fire extinguisher, type ABE class III
- Clear laminated glass (front and roof windows)
- Tinted toughened glass (side and rear windows)
- Sunshade kit
- Radio/CD
- Reverse camera with display integrated into main display

**Feed**

- Service winch with jib boom mounted on the feed
- Wide feed foot
- Protective guard, according to EN16228
- Screw sampler device
- Pre-split suction hood
- Auto Feed Fold

**Lubrication**

- Central lubrication system, type Lincoln
- Thread lubrication, spray system
- Artic hydraulic oil, VG 32
- Tropical hydraulic oil, VG 68
- Biological hydraulic oil, VG 46

**Hole and inclination systems**

- Hole Navigation System
- GPS compass aiming unit
- Laser receiver

**Automation and software**

- BenchREMOTE remote operator station
- Radio Remote Control
- Rig Remote Access
- Surface Manager Reporting
- Rig Access control
- Configurable safety software

**Parts and services products**

- ROC Care

**Optional accessories**

- Tool kit for rotary head with fixed spindle sub
- Tool kit for rotary head with floating spindle sub
- Lubrication kit
- RCS tool box

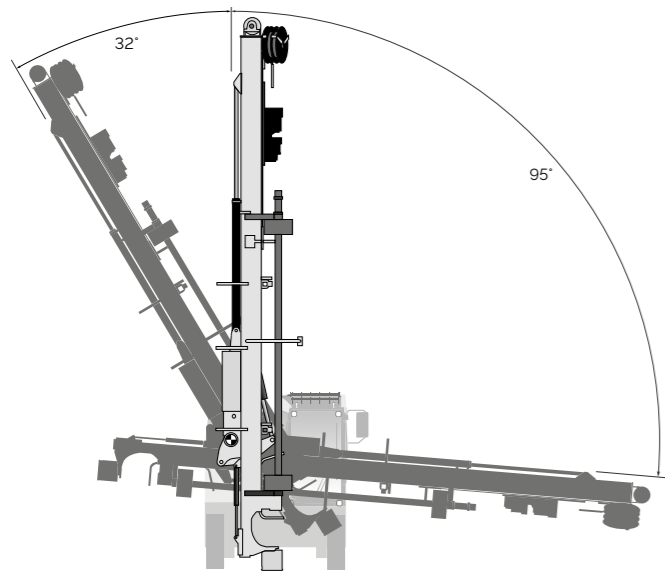

Standard feed swing angles

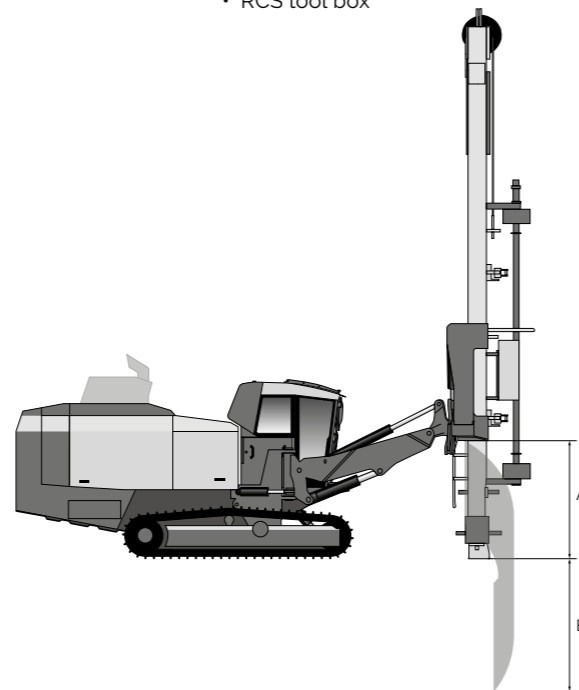

**Vertical reach**

	A (Metric)	B (Metric)	A (US)	B (US)
Standard feed	1 040 mm	2 659 mm	41'	105'

**Height and length**

Standard Feed (SF) dumped		
	Metric	US
Height (H1)	3 500 mm	138'
Length (L1)	11 350 mm	447'
Feed height		
	Metric	US
Standard Feed (H2)	9 400 mm	370'
Body height		
	Metric	US
Height Tier 4 (C)	3 700 mm	146'
Height Tier 3 (D)	3 030 mm	120'
Length		
	Metric	US
Body length (E)	5 450 mm	215'
Crawler track length (F)	3 500 mm	138'

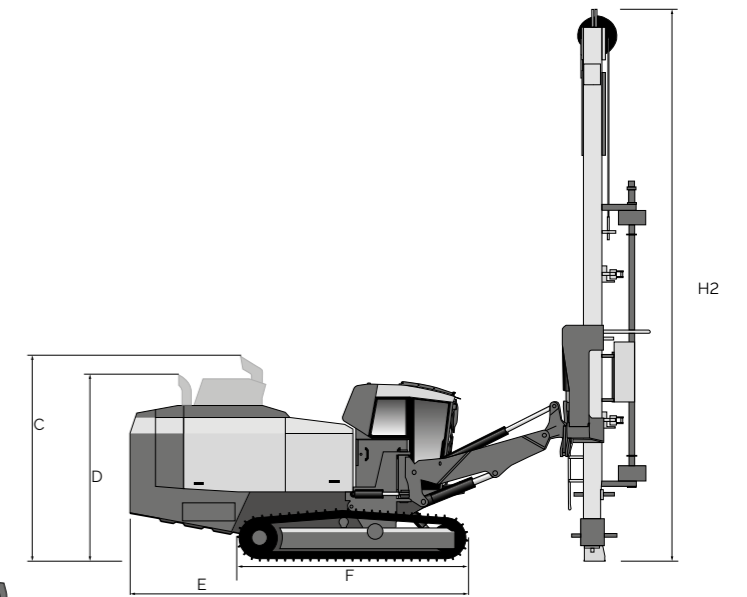
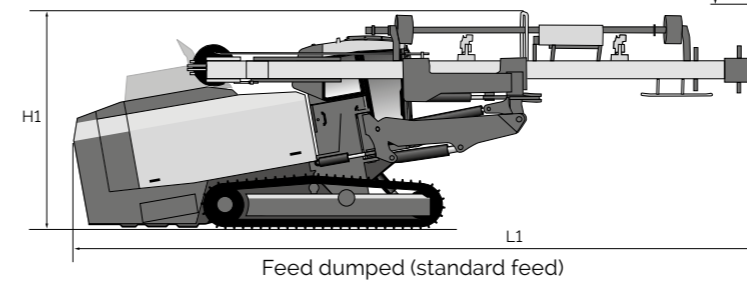

Height and length

**Weight\***

	Metric	US
SmartROC D50	24 500 kg (T3)	54 000 lb
	24 500 kg (T4)	54 000 lb

\*Weight excludes RDT and widening kit

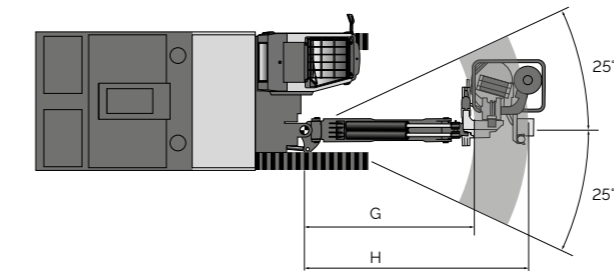

**Horizontal reach**

	Metric	US
Standard feed (G)	2 700 mm	106'
Standard feed (H)	3 190 mm	126'

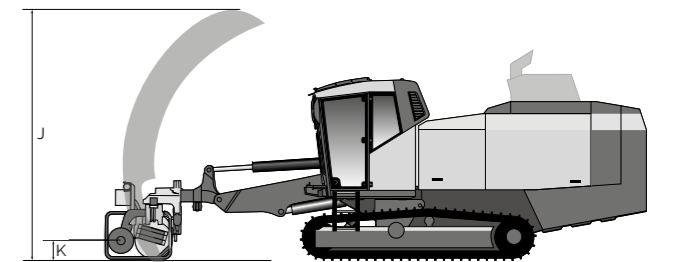

**Toe-hole drilling**

	Metric	US
Standard feed (J)	4 230 mm	167'
Standard feed (K)	642 mm	25'

**Width**

	Metric	US
Width including wide kit option (L)	3 000 mm	118'
Standard width (M)	2 500 mm	99'
Crawler track width (N)	330 mm	13'

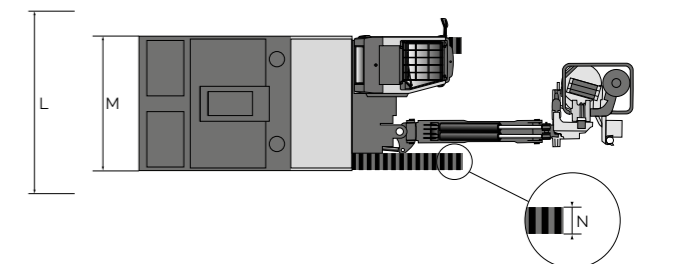



9868 0293 01 2020-04 Epiroc Sweden. Legal Notice © Copyright 2020 Epiroc Rock Drills AB, Epiroc Sweden. All product names in this publication are trademarks of Epiroc. Any unauthorized use or copying of the contents or any part thereof is prohibited. Illustrations and photos may show equipment with optional extras. No warranty is made regarding specifications or otherwise. Specifications and equipment are subject to change without notice. Consult your Epiroc Customer Center for specific information.

# United in performance. Inspired by innovation.

Performance unites us, innovation inspires us, and commitment drives us to keep moving forward. Count on Epiroc to deliver the solutions you need to succeed today and the technology to lead tomorrow.  
**[epiroc.com](http://epiroc.com)**

