

# PowerROC T35 E

Surface drill rig for construction, road construction and urban development

Hole diameter: 64–102 mm (2 ½"–4")







# Born to ROC

Come rain or shine – the new PowerROC T35 E is a partner that won't let you down. Thanks to its straight-forward design, the robust Epiroc components and impressive power.

Due to the COP Logic control system as the standard configuration which ensures the good contact with the rock and the high drilling quality, together with the extendable boom which can easily realize the quick positioning and

long reach, the PowerROC T35 E is the strong choice in a variety of construction settings, including housing foundations, road building, pipe line building and trenching.

## ⊕ Main benefits

**Higher productivity** with increased air and Epiroc COP rock drills as a standard feature

**Improved performance** due to less maintenance with a reliable control system and ergonomic design

**Fast penetration rates** – more meters per liter fuel means greater cost efficiency



# A new rig for a tough gig

The easy-to-operate PowerROC T35 E is a powerful and reliable surface drill rig without cabin, loaded with proven Epiroc technology for higher productivity, low maintenance and quality drilling.



## + Aluminum feed for straighter holes

PowerROC T35 E is equipped with an aluminum feed system. It provides straighter holes compared to steel feed. The drilling and tramming controls are located in three places on the machine, which enables safe and efficient operation even in risky environments. Add the Epiroc COP rock drill and the COP Logic control system, which are standard features, and you will have full control over your operation, wherever your business takes you.



## + Easy maintenance and serviceability

The PowerROC T35 E is ergonomically designed with the operator's safety in mind. All service points are within easy reach, which means easy access and easy maintenance on the ground.



## + Operation in a comfortable manner

The rig has a swing arm for better comfort and higher safety. The operator does not have to stand next to the feed which means less dust and noise exposure. PowerROC T35 E also has excellent terrain maneuverability. The low overall height of the machine makes it simple to handle and easy to transport.

## A comprehensive service offering

Even the best equipment needs to be serviced regularly to make sure it sustains peak performance. An Epiroc service solution offers peace of mind, maximizing availability and performance throughout the lifetime of your equipment. We focus on safety, productivity and reliability.

By combining genuine parts and an Epiroc service from our certified technicians, we safeguard your productivity – wherever you are.

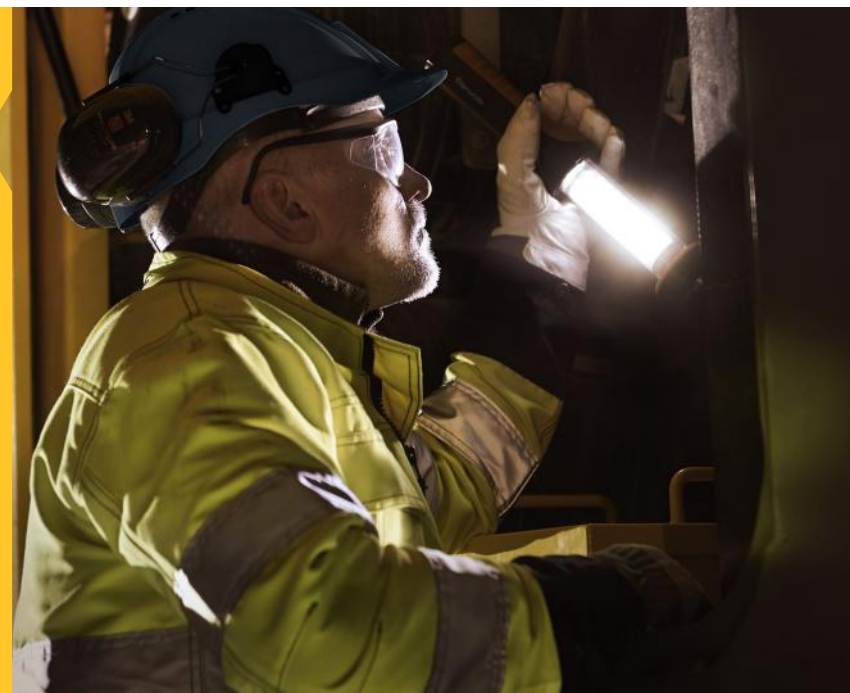

## Technical specifications

### Main components

- Track frames with single grouser pads, hydraulic track oscillation and two speed traction
- Tier 3 (Stage IIIA) diesel engine size Cummins QSB6.7 142 Kw
- Tier 4 (Stage IIIB) diesel engine size Cummins QSB6.7 150 Kw
- Screw type air compressor
- 3 ft / 800 mm extendable boom system
- Cylinder driven aluminium feed system

- Long feed with 22ft/6.7m single pass
- Carousel type rod handling system
- Hydraulic rock drill
- Dust collection system
- Both side (L/R) traction/position control (short feed), single side traction/position control (long feed)
- Swing arm type control panel

### Engine

Cummins turbo charged diesel engine, QSB6.7 Tier 3	Metric	US
Power rating at 2 300 rpm	142 kW	190 hp
Cummins turbo charged diesel engine, QSB6.7 Tier 4		
Power rating at 2 500 rpm	145 kW	195 hp

### Compressor

Atlas Copco C111, screw compressor	Metric	US
Working pressure, max	9.7 bar	141 psi
FAD, at normal working pressure	132 L/s	275 cfm

### Hydraulic system

Hydraulic oil cooler	Metric	US
Max ambient temperature	50°C	122°F

### Feed

Hydraulic cylinder feed with hose guide and double drill tube support with break-out table and movable lower guide/dust hood	Metric	US
Feed extension	1 500 mm	59'
Feed rate, max	0.85 m/s	167 ft./min
Feed force, max	19.6 kN	4 406 lbf
Tractive pull, max	19.6 kN	4 406 lbf
Travel length	4 400 mm	174'

### Dust collector

	Metric	US
Filter area	18.4 m <sup>2</sup>	198 sq.ft
Number of filter elements	8 pcs	8 pcs
Cleaning air pressure, max	4.0 bar	58.0 psi
Cleaning air volume	17-34 L/pulse	170N L/min

### Electrical system

Voltage	24 V
Batteries	2 x 12 V, 96 Ah
Alternator	24 V, 70 A
Work lights, front	2 x 70 W
Work lights, rear	1 x 70 W
Warning lamp and reverse buzzer	

### Volumes

Hydraulic oil tank	200 l	53 US gal
Hydraulic system, total	280 l	74 US gal
Compressor oil	27 l	6.6 US gal
Diesel engine oil	25 l	6.1 US gal
Diesel engine, cooling water	33 l	8.7 US gal
Diesel engine, fuel tank	380 l	100 US gal

### Hydraulic rock drill

Rock drill	Impact power	Hydraulic pressure	Impact rate	Max torque	Weight approx
KOP 1750	17 kW (22.8 hp)	142 bar (2 060 psi)	43 Hz	715 Nm (527 lbf-ft)	230 kg (507 lb)
COP 1840+	19 kW (25.5 hp)	220 bar (3 190 psi)	49 Hz	700 Nm (516 lbf-ft)	193 kg (425 lb)
COP 1840 EX*				*980 Nm (723 lbf-ft)	247 kg (544 lb)

\* With 09 high torque rotation motor

### Hole range (recommended)

Type of drilling	Drill steel type	Drilling diameter	Max hole depth	Drill steel length
Single pass	Short feed	64-102 mm (2 ½-4')	3.6 m (12')	4 270 mm (14')
	Long feed		6.0 m (20')	6700 mm (3050 mm + 3660 mm) / 22'(10+12')
Extension drilling	Short feed	64-102 mm (2 ½-4')	25 m (82')	4270 mm (14') x 1 + 3660 mm (12') x 6
	Long feed		9.6 m (31.5')	6700 mm (22') x 1 + 3660 mm (12') x 1

# Technical specifications

Wide drilling coverage with center pin boom swing.

Hydraulic cylinder feed system employs rigid aluminum feed beam with precise feed force for long drill steel life and straight holes.

Foldable swing arm. The control panel is adjustable in height for slope stabilization. Wide horizontal at height drilling for multi-drilling application. Provides better comfort and higher safety.

Winch option available for drilling in gradients.

On both sides: Trimming platform with trimming panel and safety bars with support for the back, provides comfortable operator environment in any drilling conditions.

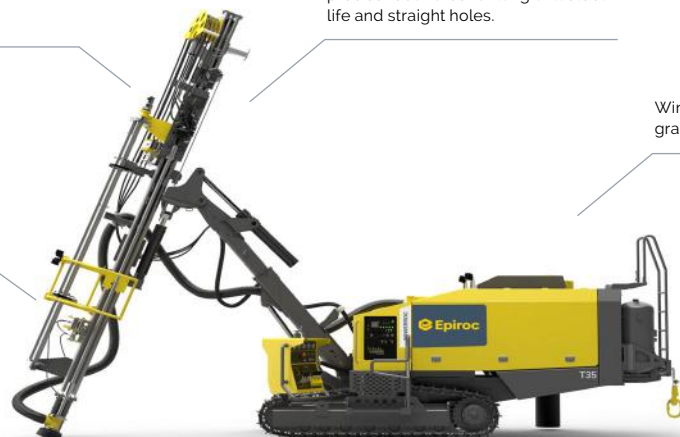

## Transport dimensions

	Metric	US
<b>Height and length</b>		
<b>Tramming</b>		
Height	3 527 mm (SF)	138.9'
	3 450 mm (LF)	135.8'
Length	9 289 mm (SF)	365.7'
	9 300 mm (LF)	366.1'
<b>Transport</b>		
Height	2 615 mm (SF)	103'
	2 950 mm (LF)	116'
Length	9 849 mm (SF)	387.8'
	10 540 mm (LF)	415'
Width	2 360 mm	93'
<b>Feed height</b>		
H1	7 816 mm (SF)	307.7'
	9 250 mm (LF)	364.2'
H2	2 511 mm	98.9'
l1	3 160 mm	142.1'
l2	4 856 mm	191.2'
<b>Weight</b>		
	12 500 kg	27 557 lb

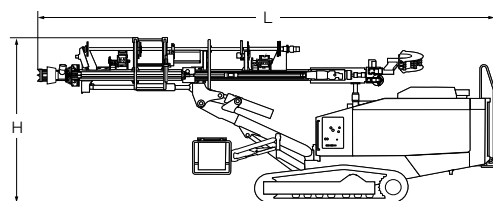
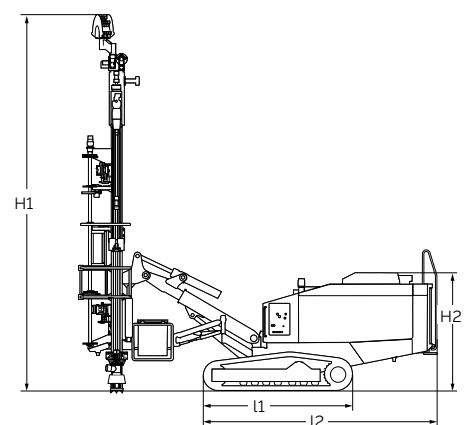

# Technical specifications

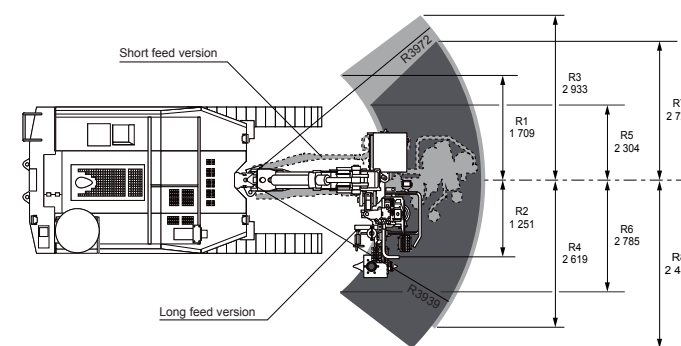

Horizontal reach (mm)

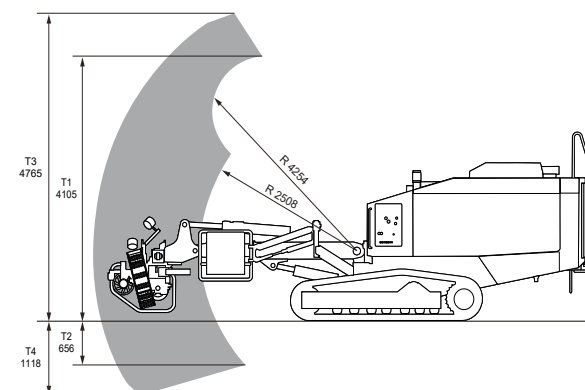

Toe hole drilling with re-pinning (mm, short feed)

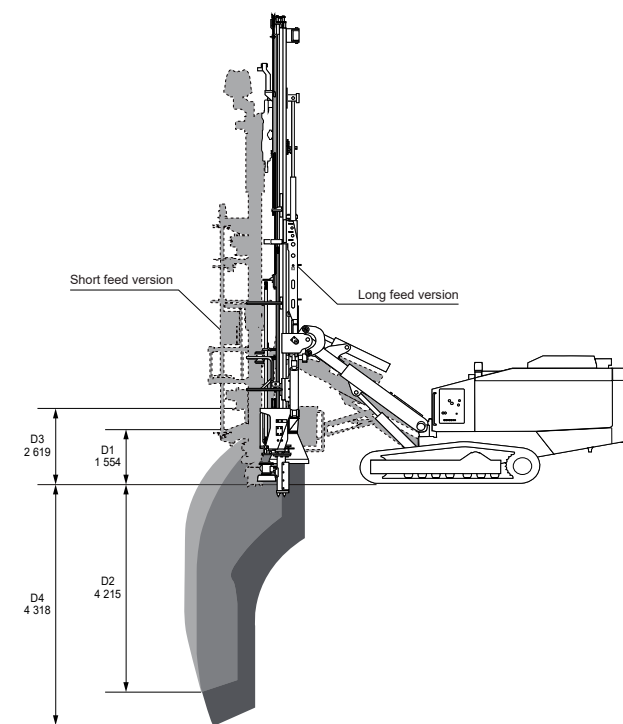

Vertical reach (mm)

## Selection of options

### Carrier

- Track chains with single grouser pads
- Track chains with triple grouser pads
- Super rotation system
- Hydraulic winch
- ROC Care components

### Safety cabin

- Revolving light kit
- Side view mirror kit
- Both side (L/R) traction/positioning system for long feed
- Lube oil, lube system and water mist system
- Water mist system (150 liters water tank)

### Hole measuring systems

- 2D angle indicator
- 3D angle indicator

### Feed

- RHS T51/72-3.66
- RHS T51S-3.66
- RHS T45/63-3.66
- RHS T45/66-3.66
- RHS T45S-3.66
- RHS T38/55-3.66
- RHS T38S-3.66

### Dust control

- Dust pre-separator

### Delivered equipment, not mounted

- Gas charging equipment for rock drill
- Hydraulic pressure test kit
- LED light kit
- Hydraulic oil filling hand pump kit

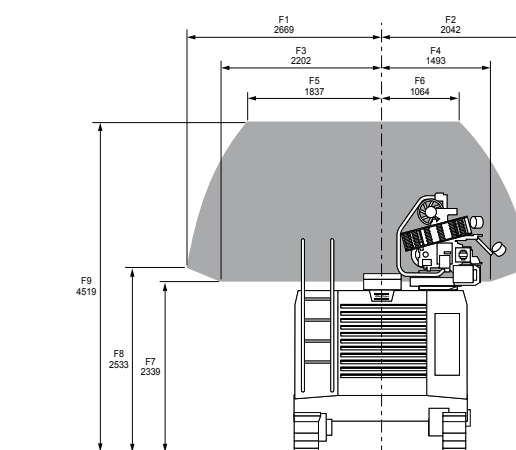

Front face horizontal drill coverage area (mm, short feed)  
Dotted area: Front coverage area with feed 7 degrees from horizontal

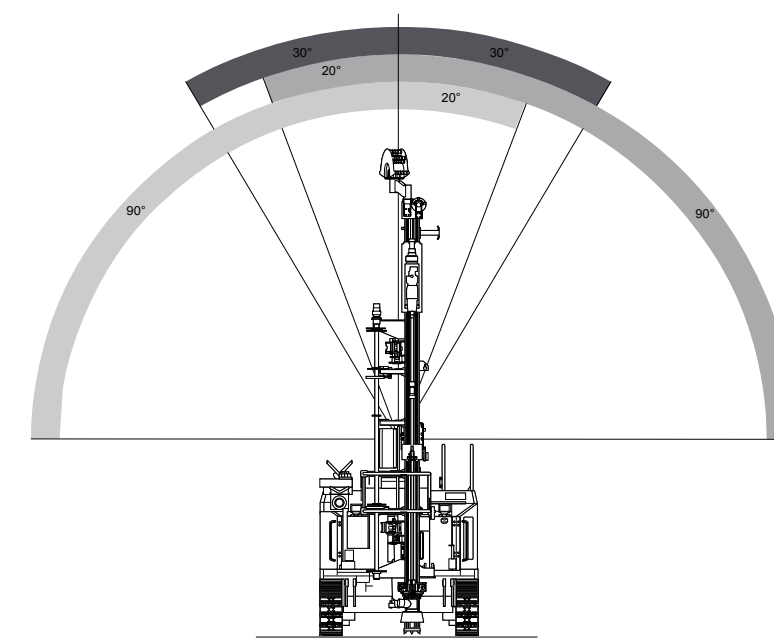

Feed swing angles, left and right

## United in performance. Inspired by innovation.

Performance unites us, innovation inspires us, and commitment drives us to keep moving forward. Count on Epiroc to deliver the solutions you need to succeed today and the technology to lead tomorrow.  
**[epiroc.com](http://epiroc.com)**

