

MIL 78000

Multiple Stage Anti-cavitation & Low Noise Control Valves





Table of Contents

Introduction	01
Features	02 - 03
Typical Applications	03
Technical Information	04 - 06
<ul style="list-style-type: none"> • Model Decodification • Standard Sizes / Ratings / End Connections • General Data • Seat Leakage Class / Temperature Range • Flow Coefficients (Rated Cv) • Actuator Selection 	
Construction	07 - 10
Dimensions and Weights	11 - 13

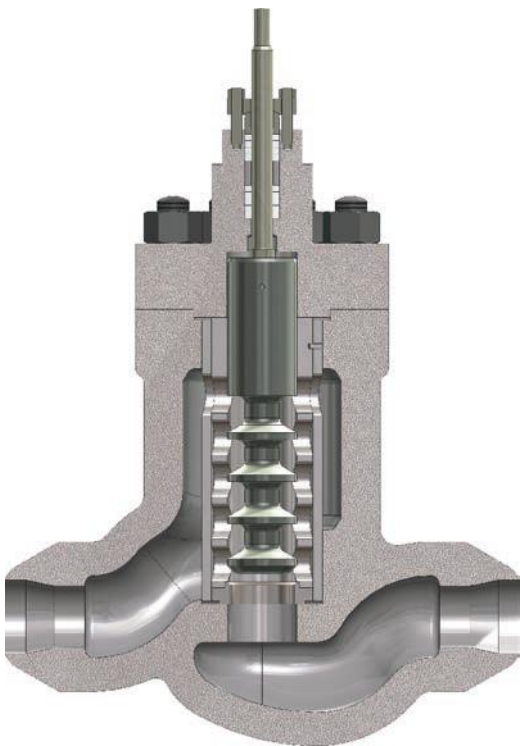

Introduction

Specially engineered control valves catering to severe service applications topped with technical innovation and extensive know-how have always been the right ingredients for a perfect severe service solution provider. Handling high pressure fluids without erosion, vibration or noise levels has been a tough problem to tackle with, for any control valve manufacturer. To exhibit unparalleled performance in high pressure critical applications, MIL offers its superior and field proven MIL 78000 series with multiple stage pressure letdown, anti-cavitation trims. The wide range of features, adaptability and ease of maintenance makes it a natural choice for severe applications and 78000 series valves have been proven as the most reliable and cost-effective anti-cavitation valve over the last 4 decades owing to a host of innovative design features.



Features

Multiple-step Axial-flow High Resistance Trim

78000 design is based on the principle of multi-step high resistance axial-flow. Pressure reduction occurs along the length of the plug through a series of throttling stages, designed to divide the total drop equally⁽¹⁾ (thereby maintains constant velocity) between the trim elements or steps. No individual stage is ever exposed to the full pressure differential and as a result, trim life is greatly extended. In addition, the fluid takes a tortuous path. This adds resistance and therefore velocity head loss.

Low Pressure Recovery

The valve trim is designed to reduce pressure recovery (exhibits high C_v) to lessen chances of vaporization at the orifice and consequently, eliminates cavitation for liquid service and contributes towards reduction of noise for all fluids. When the plug is in the wide-open position, the fluid velocity is nearly constant through the trim. The tortuous flow path adds significantly to the overall pressure losses. In the wide-open position, ideal conditions are approached, that is, continuous pressure drop and no appreciable recovery. At this point, the C_v is practically equal to 1. At reduced lift positions, the throttling mechanism is similar to a piping system with a number of single stage valves in series. Each stage throttles a portion of the total pressure drop with an increase in velocity and subsequent pressure recovery. Overall pressure recovery factor varies with the number of stages.

Special Soft Seat Design

Bubble tight leak tightness as per FCI 70.2 Class VI can be achieved when optional soft seats are supplied. The special seat ring with sliding collar shelters the resilient insert from the high-pressure fluid, when the valve opens.

High Allowable Pressure Drops

With balanced trim design for sizes 2" through 6", a wide range of allowable shut-off pressure drop is available with conventional spring diaphragm actuators.



High Performance Material is Standard

MIL 78000 series high pressure valves are manufactured from solid steel forgings to assure material integrity. Castings also available as option. Without exception, the material specified as standard have been tested and selected to provide trouble free operation in services with high pressures and erosive fluids. The high performance trim material employed ensures durability of the valve for any severe application. Special trim material available for NACE and corrosive application.

⁽¹⁾ : For incompressible fluids. For compressible fluid flow, special liner designs are employed, which maintains constant velocity.



Variety of Body Configuration Offerings

A standard angle body and optional in-line body styles are offered to accommodate a variety of piping requirements.

Large Flow Area

Because of their relatively large flow passages and shearing action provided by the multiple stage plug & cage designs, these valves are particularly well suited for applications involving fluids with entrained particles.

Simple Trim Maintenance

The multiple step trim, made from specially chosen hard material gives maximum service life and the quick change seat ring design provides ease of trim replacement.

Typical Applications

MIL 78000 series have evolved as the optimum solution for a wide spectrum of severe service applications in all industry segments.

In the Energy sector, 78000 series is the best fit solution for applications like boiler feed pump min. recirculation, spray control, low load feed water etc, where conventional control valves are plagued by problem such as shortened trim life, plug stem failure, vibration, erosion of internal components and high noise level. MIL 78000 series valves are also successfully used for start-up (low load) drum level control in lower capacity boilers, where the valves are exposed to the high pressure drop, cavitating start-up conditions.

In refinery sector, MIL 78000 series angle valves are field-proven in high pressure hydrocarbon services including amine service, where outgassing phenomenon is common. In refinery and oil & gas sector, many a times the presence of particle fines is unavoidable and the larger flow area in 78000 series allows passage of fine particles through the valve trim. Normally a valve with drilled hole or stack plate technology would get clogged when exposed to services with particulate presence. In upstream oil fields, for high pressure injection water, where presence of fine sand particles can be a concern, MIL 78000 series valves are successfully used.

MIL 78000 series valves are also commonly employed in fertilizer sector in high pressure ammonia letdown applications, where stack technology valves fails to deliver satisfactory performance.

Tight Shut-off & Seat Protection

Protection against seat erosion is ensured by provision of FCI 70.2 Class V seat shut-off when standard metal seats are furnished. Pressure reduction is accomplished between the multi-step plug & the liner and not across the seat ring. Unlike in flow tending to close designs, in MIL 78000 Series Valves the last stage pressure drop (where chances of cavitation exists) is directed well away from the seating surface. Thus in any severe service, seat ring damage due to high pressure drop can be ruled out.

Trim characteristic

MIL 78000 series valves have an inherent Mod. Linear characteristic, integrating the clearance flow concept over 10% of the initial valve travel to avoid high pressure drops in the seating area and throttling at low lifts. The 10 to 100% of the travel ensures precise control.





Technical Information

Model Decodification

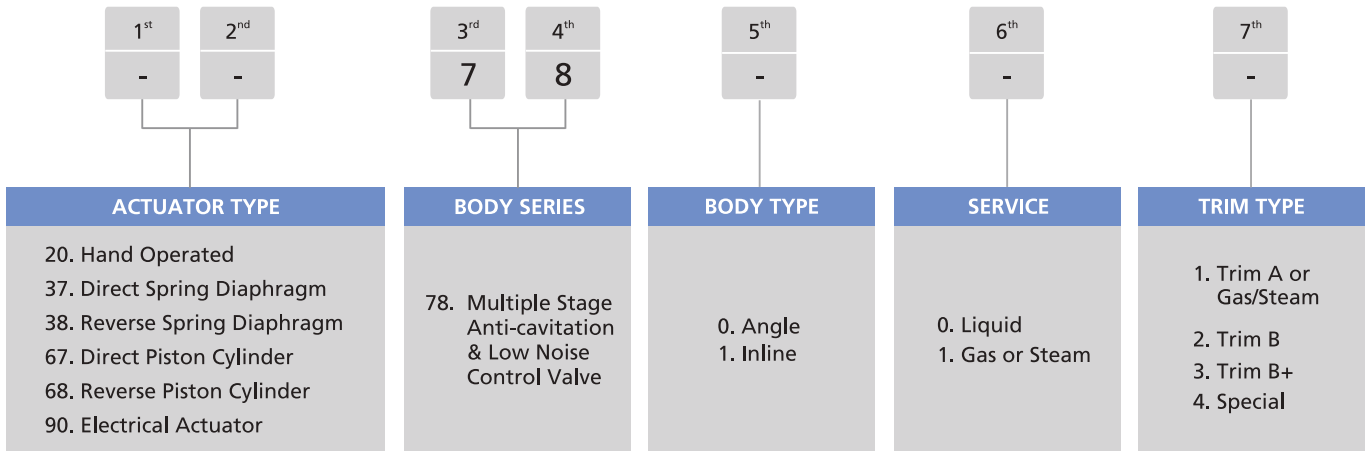

Standard Sizes / Ratings / End Connections⁽²⁾

U : Unbalanced B : Balanced

RATING ⁽³⁾ (ASME CLASS)	VALVE SIZE (inch)					
	1	1.5	2	3	4	6
≤ 600#	U	U	U B	U B	U B	U B
900# - 2500#	U	U	U B	U B	U B	U B

⁽²⁾ : MIL 78000 Series valves are available in Flanged & Weld end constructions. Size-wise availability listed in Page 11

⁽³⁾ : DIN, JIS, BS or other ratings & end connections can be usually supplied, consult MIL

General Data

BODY	
Type	: Inline or Angle Castings or Forgings
Recommended Flow direction	: Flow to open
GLAND SEAL	
Type	: Adjustable double sealed packing box with PTFE or Graphite moulded split rings
Option	: Eco lock (varying density for low emission, PTFE or Graphite) or PTFE V rings
Temperature range	: ≤ 180°C PTFE, > 180°C Graphite

BONNET	
Type	: Stud bolted
Temperature range	: -29°C to 260°C
TRIM	
Type	: Multiple Step, Anti-cavitation
Plug type	: Unbalanced or pressure balanced with self energized seals (≥ 2")
Seat type	: Clamped (quick change) with metal or soft seat
Guiding	: Cage guiding
Rangeability	: 1:100
Characteristic	: Mod. Linear



Seat Leakage Class / Temperature Range

VALVE SIZE (inch)	TYPE	TEMPERATURE RANGE (°C) ⁽⁴⁾		SEAT LEAKAGE CLASS (FCI 70.2)	
		MIN	MAX	STANDARD	OPTIONAL
1 - 6	Unbalanced Metal Seat	-29	260	IV	V
2 - 6	Balanced Metal Seat	-29	232	IV	V
1 - 6	Soft Seat	-29	204	VI	

Class IV: 0.01% of maximum rated capacity at 50 psig to atmosphere

Class V: 5×10^{-4} ml/min of water per inch of orifice diameter per psi differential Class VI: Bubble Tight as per FCI 70.2

⁽⁴⁾ : Special designs available for applications outside the given temperature range, consult MIL

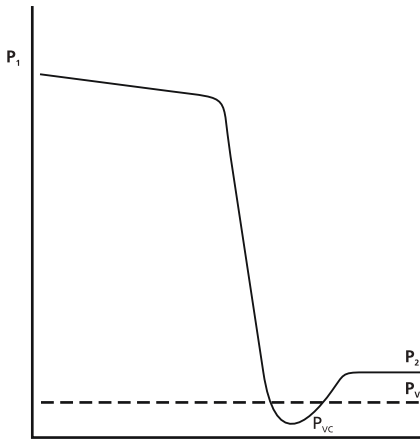

Pressure drop diagram of a conventional valve

In Cavitating Service

(Pressure drops below the vapour pressure at the vena-contracta and then recovers, resulting in cavitation.)

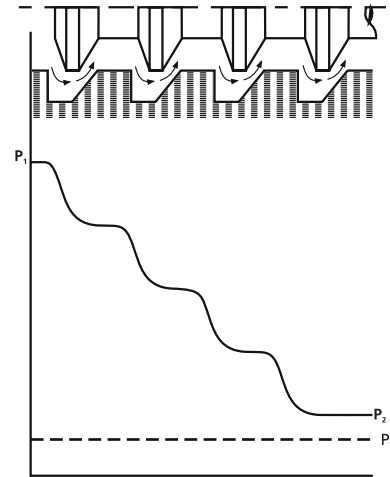

78000 plug at full open position

(Continuous pressure drop & no appreciable recovery)

Flow Coefficients (Rated Cv)

VALVE SIZE (Inch)	PRESSURE RATING (ASME Class)	ORIFICE DIA (inch)	TRAVEL (inch)	TRIM TYPE								MINIMUM OPERABLE Cv
				LIQUID						GAS OR STEAM		
				A		B		B+		C _f	C _v	
				C _f	C _v	C _f	C _v	C _f	C _v			
1	≤2500#	0.5	0.125	0.998	0.1, 0.3	0.992	0.6	0.985	0.9, 1.1	0.97	0.75	0.03
1.5	≤2500#	1	0.25	0.997	0.9, 1.2	0.991	2.4	0.982	3.6, 4.5	0.97	3, 3.5	0.06
2	≤2500#	1.875	0.50	0.997	1.2, 2.4, 4	0.991	6, 8	0.982	12, 15	0.97	13	0.12
3X2	900-2500#	1.875	0.50	0.997	1.2, 2.4, 4	0.991	6, 8	0.982	12, 15	0.97	13	0.12
4X2	900-2500#	1.875	0.50	0.997	1.2, 2.4, 4	0.991	6, 8	0.982	12, 15	0.97	13	0.12
3	≤2500#	3.25	0.88	0.997	15	0.988	30	0.978	40, 55, 70 ⁽⁵⁾	0.97	40	0.61
4X3	≤2500#	3.25	0.88	0.997	15	0.988	30	0.978	40, 55, 70 ⁽⁵⁾	0.97	40	0.61
6X3	≤600#	3.25	0.88	-	-	-	-	0.978	40, 55, 70 ⁽⁵⁾	0.97	60	1.5
6X3	≥900#	3.25	0.88	0.997	15	0.988	30	0.978	40, 55, 70 ⁽⁵⁾	0.97	40	0.61

⁽⁵⁾ : Cv - 70 with cast body upto ANSI Class 600#

* Critical flow factor : C_f or F_L



Actuator Selection

(Balanced Valves)

VALVE SIZE (inch)	MAX RATING (ASME Class)	STROKE (inch)	ACTUATOR SIZE	ACTUATOR TYPE : 37 DIRECT (ACTION : AIR TO CLOSE)				ACTUATOR TYPE : 38 REVERSE (ACTION : AIR TO OPEN)			
				SPRING RANGE (psig)	SUPPLY PRESSURE (psig)	SHUT OFF PRESSURE (kg/cm ² g)		SPRING RANGE (psig)	SUPPLY PRESSURE (psig)	SHUT OFF PRESSURE (kg/cm ² g)	
						IV ⁽⁶⁾ & V ⁽⁶⁾	VI ⁽⁶⁾			IV ⁽⁶⁾ & V ⁽⁶⁾	VI ⁽⁶⁾
2	2500#	0.5	15	6-16	35	210	210	16-25	30	210	210
				6-16	45	420	420	24-31	40	386	344
3	2500#	0.88	18	3-15	40	210	210	18-30	35	140	77
				3-15	50	420	330	18-30	35	228	109
4	2500#	0.88	18	3-15	40	210	210	18-30	35	140	77
				3-15	50	420	330	18-30	35	228	109
6	2500#	0.88	18	3-15	40	210	210	18-30	35	140	77
				3-15	50	420	330	18-30	35	228	109

Actuator Selection

(Unbalanced Valves)

VALVE SIZE (inch)	MAX RATING (ASME Class)	STROKE (inch)	ACTUATOR SIZE	ACTUATOR TYPE : 37 DIRECT (ACTION : AIR TO CLOSE)				ACTUATOR TYPE : 38 REVERSE (ACTION : AIR TO OPEN)			
				SPRING RANGE (psig)	SUPPLY PRESSURE (psig)	SHUT OFF PRESSURE (kg/cm ² g)		SPRING RANGE (psig)	SUPPLY PRESSURE (psig)	SHUT OFF PRESSURE (kg/cm ² g)	
						IV ⁽⁶⁾ & V ⁽⁶⁾	VI ⁽⁶⁾			IV ⁽⁶⁾ & V ⁽⁶⁾	VI ⁽⁶⁾
1	2500#	0.125	13	6-10	25	210	210	12-16	25	210	210
				6-10	30	420	420	18-22	30	420	420
1.5	2500#	0.25	15	6-12	35	210	210	24-30	35	175	175
				6-12	50	420	420	24-30	35	316	316
2	2500#	0.5	15	6-16	45	70	70	16-25	30	35	35
				6-16	55	140	140	24-31	40	60	60
3	2500#	0.88	18	3-15	40	28	28	18-30	35	17	14
				3-15	60	70	63	18-30	35	28	21
4	2500#	0.88	18	3-15	40	28	28	18-30	35	17	14
				3-15	60	70	63	18-30	35	28	21
6	2500#	0.88	18	3-15	40	28	28	18-30	35	17	14
				3-15	60	70	63	18-30	35	28	21

⁽⁶⁾ : Seat leakage class IV, V and VI as per FCI 70.2



Construction

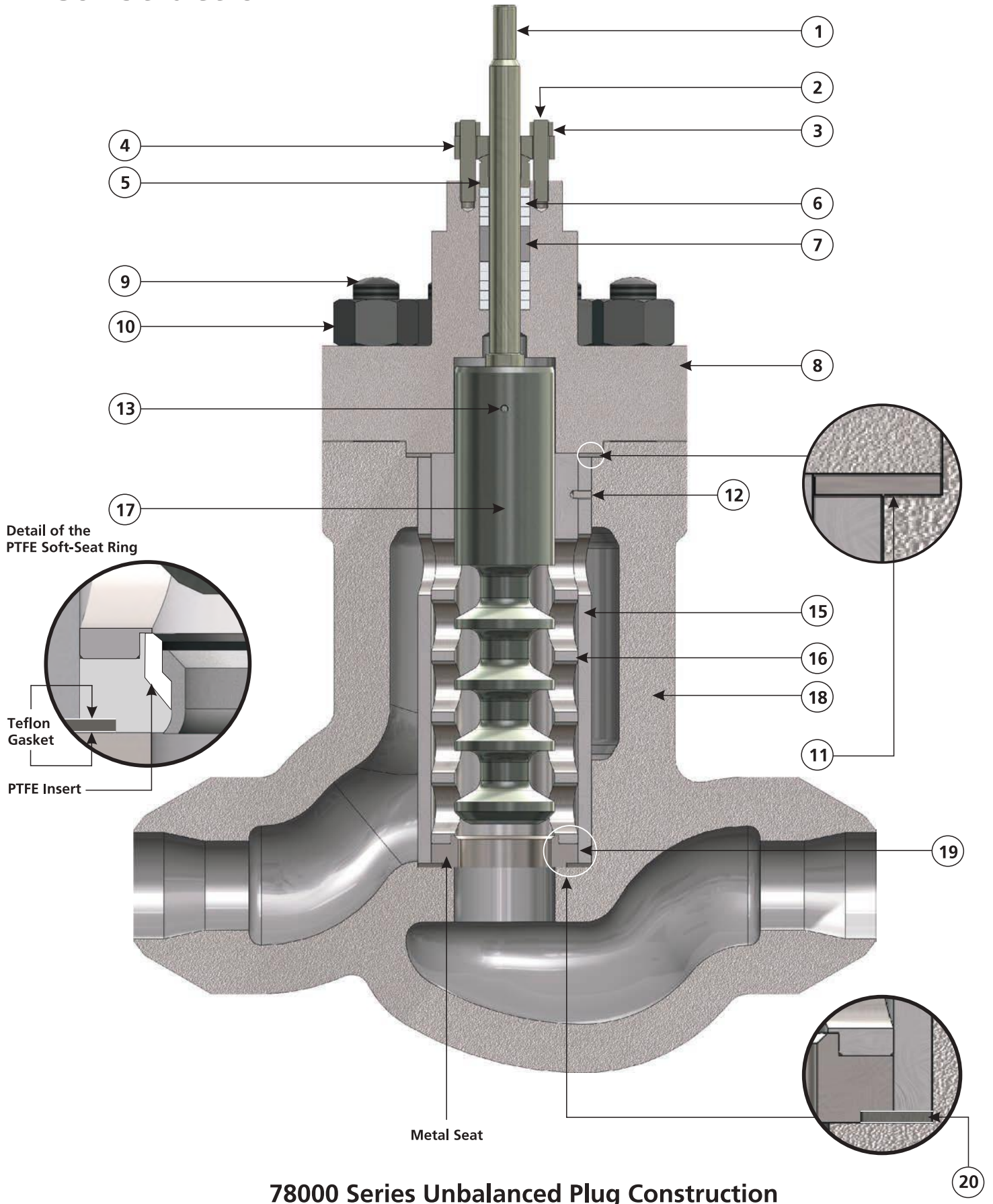



Material of Construction

DRAWING REF. NO.	PART NAME	STANDARD MATERIAL *
1	Valve Plug Stem	17.4 PH SST H1075
2	Packing Flange Stud	ASTM A 193 Gr. B8
3	Packing Flange Nut	ASTM A 194 Gr. 8
4	Packing Flange	ASTM A 105
5	Packing Follower	304 SST
6	Gland Packing	PTFE $\leq 180^{\circ}\text{C}$ / Graphite $> 180^{\circ}\text{C}$
7	Packing Spacer/Lantern Ring	304 SST
8, 18	Valve Body, Bonnet	Carbon Steel : ASTM A 216 Gr. WCC / ASTM A 105
		Alloy Steel : ASTM A 217 Gr. WC6 / WC9 ASTM A 182 Gr. F11 / F22
		Stainless Steel : ASTM A 351 Gr. CF8M / ASTM A 182 Gr. F316
9	Body Stud	ASTM A 193 Gr. B7
10	Body Nut	ASTM A 194 Gr. 2H
11	Body Gasket	316L SST + Graphite
12, 13	Roll Pin, Plug Pin	ASTM A 276 Type. 420 (Roll Pin), 316 SST (Plug Pin)
14	Balancing Seal Set ⁽⁷⁾	Spring energised Ekonol + PTFE $< 232^{\circ}\text{C}$
15	Spacer	17.4 PH SST H1075
16	Liner	17.4 PH SST H1075
17	Plug	440C SST Heat Treated
19	Seat Ring	316 SST + Stellite No. 6 or PTFE
20	Seat Ring Gasket	316L SST + Graphite

⁽⁷⁾ : For balanced construction only, Refer page 09

* Material indicated above are for reference only. MIL reserves the right to supply alternate material due to constant product upgradation. Other specific material are available on request.



Construction

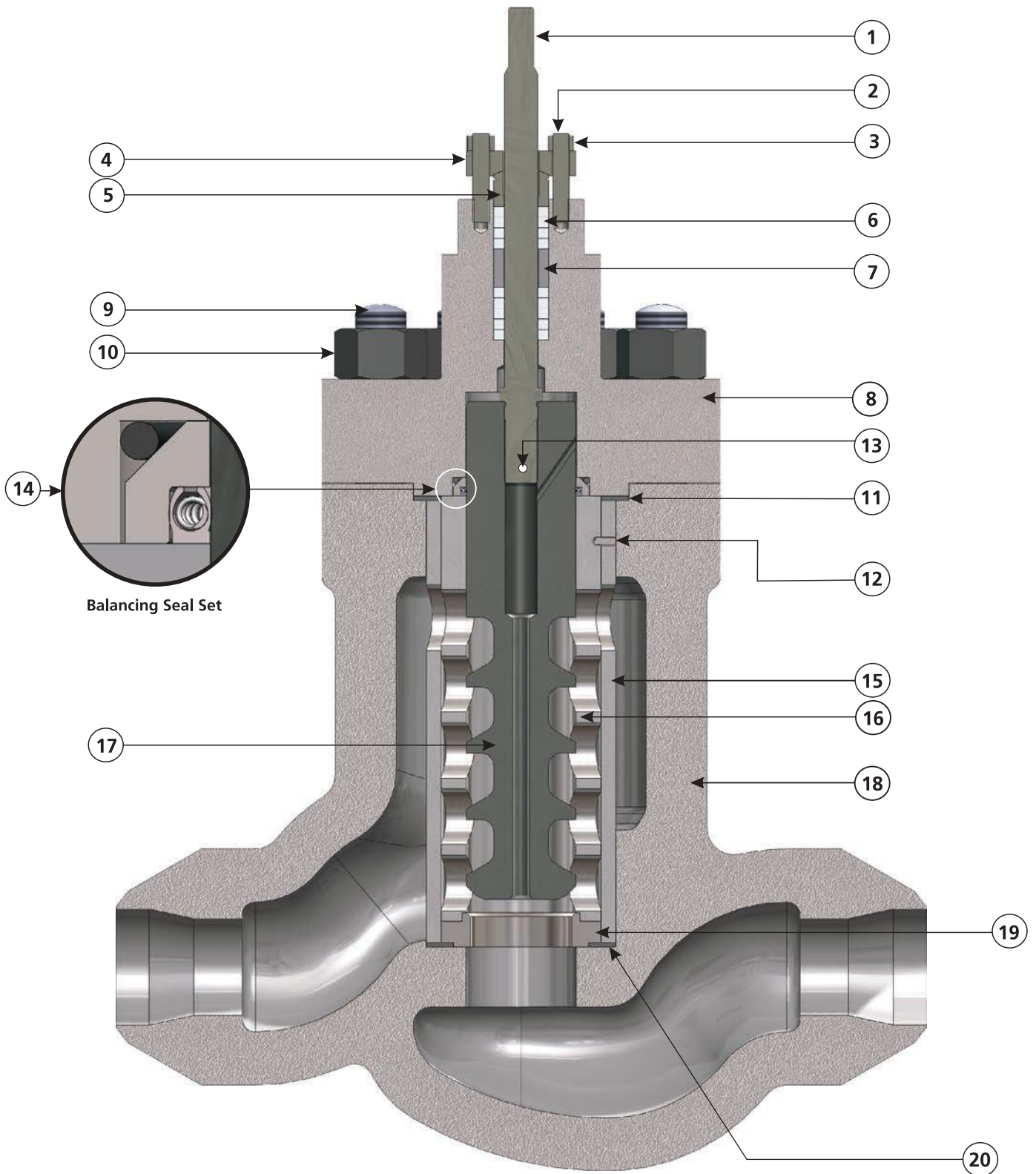

78000 Series Balanced Plug Construction



Optional Material for Corrosive Service

DRAWING REF. NO.	PART NAME	STANDARD MATERIAL*	
1	Valve Plug Stem	Inconel X-750	
2	Packing Flange Stud	ASTM A 193 Gr. B8	
3	Packing Flange Nut	ASTM A 194 Gr. 8	
4	Packing Flange	ASTM A 105	
5	Packing Follower	304 SST	
6	Gland Packing	PTFE $\leq 180^{\circ}\text{C}$ / Graphite $> 180^{\circ}\text{C}$	
7	Packing Spacer/Lantern Ring	304 SST	
8, 18	Valve Body, Bonnet	Carbon Steel : ASTM A 216 Gr. WCC / ASTM A 105	
		Alloy Steel : ASTM A 217 Gr. WC6 / WC9 / ASTM A 182 Gr. F11 / F22	
		Stainless Steel : ASTM A 351 Gr. CF8M / ASTM A 182 Gr. F316	
9	Body Stud	ASTM A 193 Gr. B7	
10	Body Nut	ASTM A 194 Gr 2H	
11	Body Gasket	316L SST + Graphite	
12, 13	Roll Pin, Plug Pin	316 SST	
14	Balancing Seal Set ⁽⁷⁾	Spring Energised Ekonol + PTFE $< 232^{\circ}\text{C}$	
15	Spacer	Standard	17.4 PH SST H1150M
		Optional	Ferralium 255, ASTM A 351 Gr. CD4MCU, Monel K500, Inconel X-750 (HRC 35 max.)
16	Liner	Standard	17.4 PH SST H1150M
		Optional	Ferralium 255, ASTM A 351 Gr. CD4MCU, Monel K500, Inconel X-750 (HRC 35 max.)
17	Plug	Standard	Monel K500
		Optional	Nitronic 60, ASTM A479 Type S21800 with hard facing on seat area, Nitronic 50, ASTM A479 Type XM-19 with HF on seat & guide area (HRC 35 max.)
19	Seat Ring	316 SST + Stellite No.6 or PTFE	
20	Seat Ring Gasket	316L SST + Graphite	

⁽⁷⁾ : For balanced construction only, Refer page 09

*Material indicated above are for reference only. MIL reserves the right to supply alternate material due to constant product upgradation. Other specific material are available on request.



Casting and Forging Availability

VALVE SIZE (inch)	END CONNECTION	INLINE VALVES						ANGLE VALVES					
		150#	300#	600#	900#	1500#	2500#	150#	300#	600#	900#	1500#	2500#
1	RF			F	F	F					F	F	
	RTJ				F	F					F	F	F
	WE				F	F	CF				F	F	F
1.5	RF			F	CF	CF	C					CF	C
	RTJ			F	CF	CF	C					CF	C
	WE				CF	CF	CF				CF	CF	F
2	RF	F		CF	CF	CF	CF			C		F	F
	RTJ			C	CF	CF	CF			C		F	F
	WE	C	C	C	CF	CF	CF				F	F	F
3	RF		F		C	C	F				C	C	
	RTJ				C	C	F				C	C	
	WE	F	F	F	C	C	C	F	F	F	CF	CF	F
4x2	RF						C						
	RTJ						C						
	WE				CF	CF	CF						
4x3	RF			C	C	C	C				C	C	F
	RTJ			C	C	C	C				C	CF	
	WE				CF	CF	CF	C	C	C	C	C	
6	RF			C							C		
	RTJ			C							C		
	WE	C	C	C				C	C	C			
6x3	RF			C	C	C	C				C	C	
	RTJ			C	C	C	C				CF	CF	
	WE				CF	CF	CF	C	C	C	C	C	
8	RF				C						C		
	RTJ				C						C		
	WE												

C : Cast Body Available F : Forged Body Available

Dimensions and Weights

Angle Forging

VALVE SIZE (inch)	RATING (ASME Class)	END CONNECTION	A (mm)	B (mm)	H (mm)	UNPACKED WEIGHT (kg)
1	1500#	RF	60.5	101.5	175	35
1	2500#	SW	65	101.5	175	37
1	2500#	RTJ	60.5	101.5	175	35
1.5	2500#	SW	80	117	215	57
1.5	2500#	BW	119	119	215	62
2	1500#-2500#	RTJ	98.5	152.5	280	115
2	1500#	RF	98.5	152.5	280	115
2	2500#	BW	165	177.5	280	130
3	2500#	BW	190	272	390	350
4x3	2500#	RF	200	227	374	445
6x3	1500#	RTJ	220	280	391	820

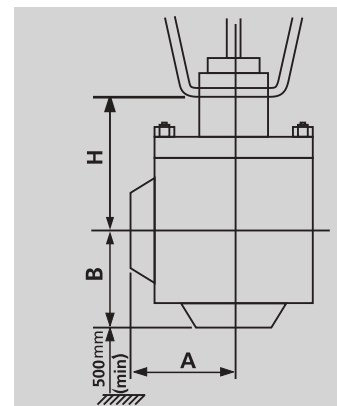



Inline Forging

VALVE SIZE (inch)	PRESSURE RATING (ASME Class)	END CONNECTION	A (mm)	B (mm)	H (mm)	UNPACKED WEIGHT (kg)
1	1500#	RF/RTJ	333	90	290	56
1	2500#	BW/SW	300	73	290	41
1	600#	RF	286	83	390	100
1.5	1500#	RTJ	610	150	492	355
1.5	1500#	RTJ	610	155	538	515
1.5	2500#	RTJ	610	178	538	425
1.5	600#	BW	610	150	492	320
2	1500#	RF	394	108	404	155
2	2500#	RTJ	289	82	390	100
2	150#	RTJ	394	108	404	155
3	600#	BW	302	71	390	72
3X2	2500#	BW	451	86	404	120
3X2	900#	RF	610	155	535	455
4X3	2500#	RTJ/BW	610	155	538	455
4X2	2500#	RF	610	150	495	360

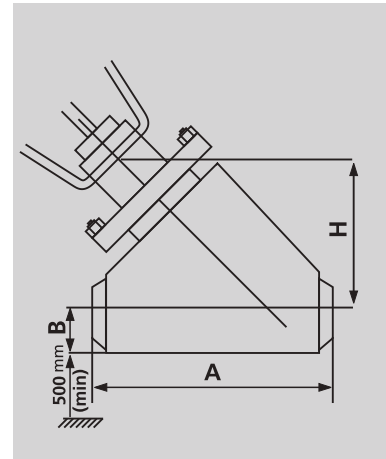

Angle Casting

VALVE SIZE (inch)	RATING (ASME Class)	END CONNECTION	A (mm)	B (mm)	H (mm)	UNPACKED WEIGHT (kg)
1	900/1500/2500#	BW	95	104	179	35
1	900/1500/2500#	SW	65	102	179	35
1.5	1500#	RTJ	195	195	220	45
1.5	900/1500/2500#	BW	119	119	217	41
1.5	900/1500/2500#	SW	80	117	217	41
2	900/1500/2500#	BW	165	178	283	75
2	900/1500/2500#	SW	100	163	283	75
3	900/1500/2500#	BW	225	235	375	305
3	900/1500/2500#	SW	150	216	375	305
4	150/300/600#	BW	216	337	280	265
6	150/300/600#	BW	328	355	575	420
4x2	900/1500/2500#	BW	165	178	283	265
4x3	900/1500#	RTJ	305	305	375	350
4x3	150/300/600#	BW	216	337	279	265
4x3	150/300/600#	WE	216	337	280	265
6x3	900/1500#	RTJ	382	382	392	570
6x3	150/300/600#	BW	216	337	279	340
6x3	900/1500/2500#	BW	205	271	376	440

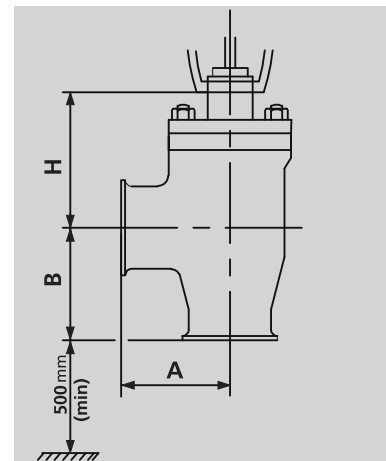



Inline Casting

VALVE SIZE (inch)	RATING (ASME Class)	END CONNECTION	A (mm)	B (mm)	H (mm)	UNPACKED WEIGHT (kg)
1.5	900/1500#	RF/RTJ	333	90	290	56
1.5	900/1500/2500#	BW/SW	300	73	290	41
2	150/300/600#	RF	286	83	390	100
2	900/1500#	RF	394	108	404	155
2	150/300/600#	RTJ	289	82	390	100
2	900/1500#	RTJ	394	108	404	155
2	150/300/600#	BW	302	71	390	72
2	900/1500/2500#	BW	451	86	404	120
3	900/1500#	RF	610	155	535	455
3	900/1500/2500#	RTJ/BW	610	155	538	455
4	300/600#	RF	610	150	495	360
4	300/600#	RTJ	610	150	492	355
4	1500#	RTJ	610	155	538	515
4	2500#	RTJ	610	178	538	425
4	150/300/600#	BW	610	150	492	320
4	900/1500/2500#	BW	610	155	538	390
6	600#	RF	610	178	495	650
6	900#	RF	760	190	538	1220
6	1500#	RTJ	760	198	538	1310
6	2500#	RTJ	874	245	538	1520
6	150/300/600#	BW	618	150	492	650
6	900#	BW	760	190	538	700
4x2	900/1500/2500#	BW	610	132	408	390
4x3	600#	RF	610	150	495	330
4x3	900/1500#	RF/RTJ	610	155	535	440
4x3	1500#	RTJ	610	155	540	475
4x3	2500#	RTJ	610	180	540	515
4x3	900/1500/2500#	BW	610	155	540	390
6x3	600#	RF	610	180	495	436
6x3	900#	RF	760	190	540	810
6x3	900/1500#	RF/RTJ	760	190	535	870
6x3	1500#	RTJ	760	200	540	870
6x3	2500#	RTJ	874	245	540	1020
6x3	900/1500#	BW	760	190	540	700

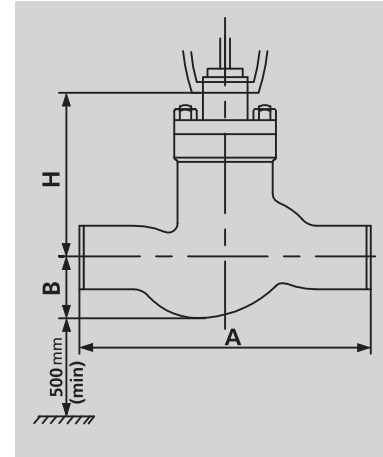



Product Highlights

- Multiple-step axial-flow high resistance trim
- Low pressure recovery
- Special soft seat design
- High allowable pressure drops
- High performance material is standard
- Variety of body configuration offerings
- Large flow area
- Simple trim maintenance
- Tight shut-off & seat protection
- Trim characteristic

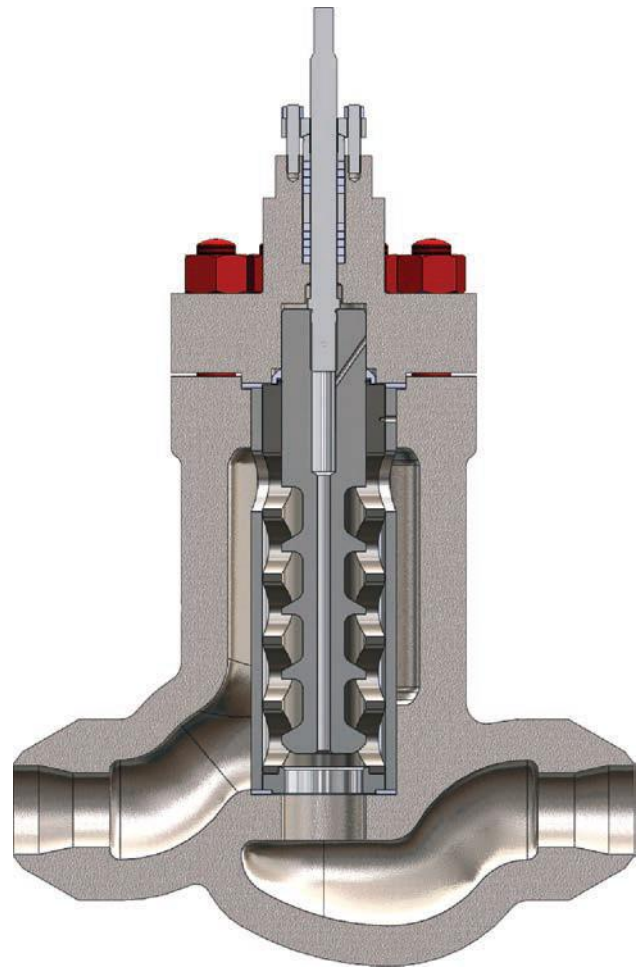

Sales & Service offices

New Delhi: MIL Controls Ltd., KSB House, A-96, Sector-4, Gautam Budh Nagar, Noida-201 301, India. Tel: +91 (120) 2541091-93, 2541501-03, Fax: +91 (120) 2550567 E-mail: salesnoida.mil@ksb.com **Mumbai:** MIL Controls Ltd., KSB Pumps Ltd., 126, Maker Chamber III, Nariman Point, Mumbai 400 021, India. Tel: +91 (22) 66588787, 66588757-59, 66588761, Fax: +91 (22) 66588788. E-mail: salesmumbai.mil@ksb.com **Kolkata:** MIL Controls Ltd., KSB Pumps Ltd., 2nd Floor, 30 Circus Avenue, Kolkata 700 017, India. Tel: +91 (33) 22809847, 22809848, 22870473, Fax: +91 (33) 22870588, 22809847. E-mail: saleskolkata.mil@ksb.com **Chennai:** MIL Controls Ltd., KSB Pumps Ltd., Guindy House, 2nd Floor, No: 95, Anna Salai, Chennai 600 032, India. Tel: +91 (44) 22352571 -72, 22300629, Fax: +91 (44) 22352749 E-mail: saleschennai.mil@ksb.com **Vadodara:** MIL Controls Ltd., KSB Pumps Ltd., 4-B, Ramakrishna Chambers, Productivity Road, Vadodara 390 005, India. Tel: +91 (265) 2330532, 2333226, Fax: +91 (265) 2350002 E-mail: salesbaroda.mil@ksb.com **Pune:** MIL Controls Ltd., KSB Pumps Ltd., Plot No - 28/21, D-II Block, MIDC, Chinchwad, Pune 411 019, India. Tel: +91 (20) 27409100, Fax: +91 (20) 27470890 E-mail: salespune.mil@ksb.com

Middle East & Asia Pacific

China: KSB Valves (Shanghai) Co.Ltd 29 F. Xing-Yuan Technology Building, 418 Guiping Road, Shanghai, China, Post Code: 200233, Tel: +86-21-6485 1778, Fax: +86-21-6485 9115. **Dubai:** KSB Middle East FZE, P.O.Box: 18315, Jebel Ali, Dubai, U.A.E. Tel: +971-4-883 0455, Fax: +971-4-883 0456 **Indonesia:** PT KSB Indonesia, Jalan Timor Blok D2-1, Kawasan Industri MM 2100 Cibitung, Jawa Barat, Indonesia. Tel: +62 21 89983570, Fax: +62 21 89983571 **Korea:** KSB Korea Ltd, Soo Young Building, 64-1, Hannam-Dong, Yongsan-Ku, Seoul 140-210, Korea. Tel: +82-2-790 4351, Fax: +82-2-790 4350 **Malaysia:** KSB Malaysia Pumps & Valves SDN BHD 29, Jalan PJU 3/47, Sunway Damansara, 47810 Petaling Jaya, Selangor Darul Ehsan, Malaysia., Tel: +60-03-7805 3397, Fax: +60-03-7805 1373 **Singapore:** KSB Singapore (Asia Pacific) PTE Ltd., 4 Woodlands Walk, Singapore 738248. Tel: 6757 7200, Fax: 6482 3005 **Taiwan:** KSB Taiwan Co.Ltd, No: 154-6 Sec 1, Datong Rd, Xizhi Dist, 10635, New Taipei City, Tel: +886-2-2649 2255, Fax: +886-2-2649 8833 **Thailand:** KSB Pumps Co Ltd., Bangkok 10530, Thailand. Tel: +66-2-988 2324, Fax: +66-2-988 2213

MIL Controls Limited
Meladoor, Annamanada, Pin 680 741,
Thrissur Dist., Kerala, India
Tel : +91 (480) 2695700
Fax : + 91 (480) 2890952
Email : sales.mil@ksb.com
Web : www.milcontrols.com



MIL

A KSB Company • **KSB** 