

Submersible Motor Pumps - KRT

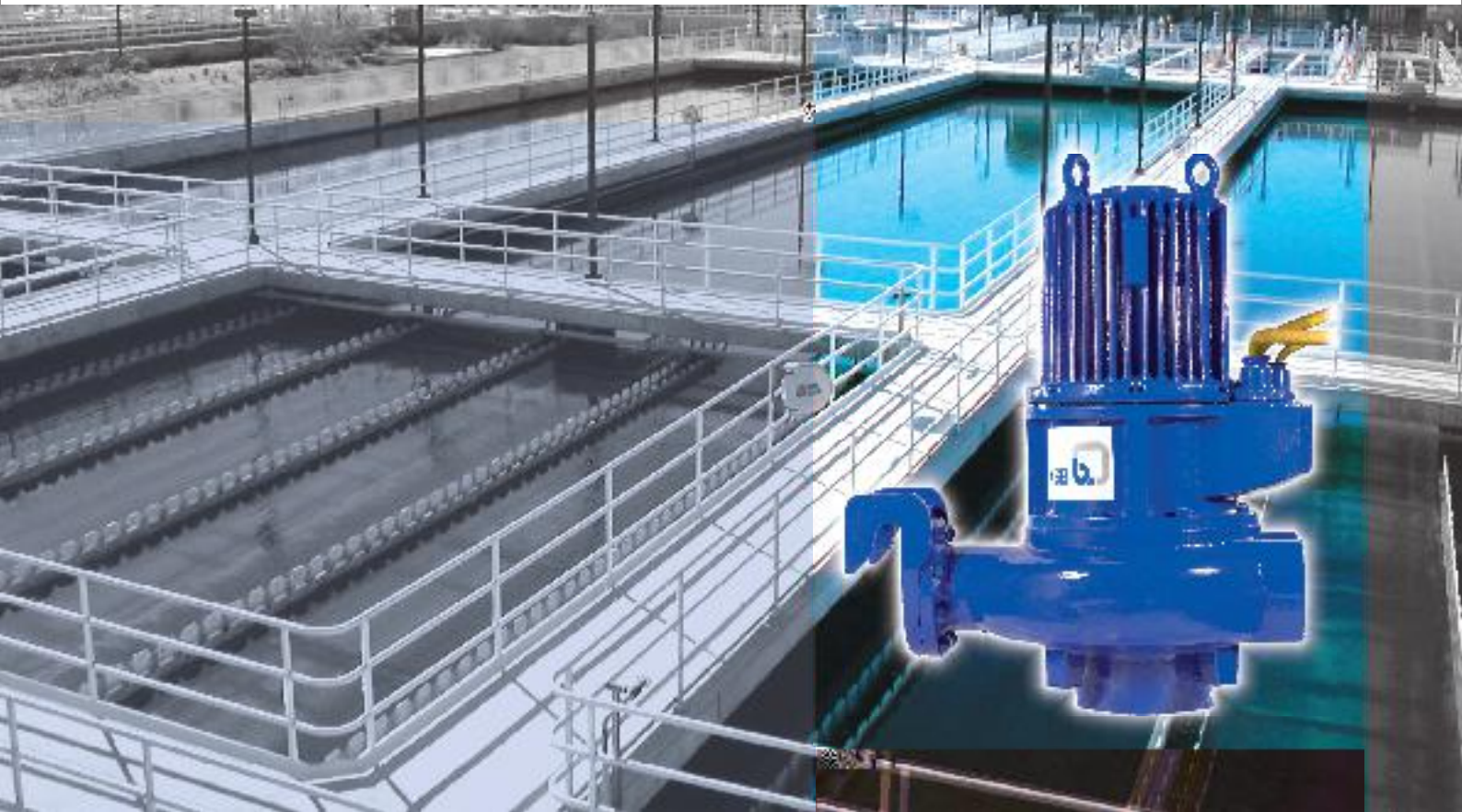

The multi-functional pump with the highest performance

The product range from KSB is the result of over 140 years of experience in pump design coupled with an in depth knowledge of different working conditions.

The submersible motor pump **KRT** overcomes all the problems associated with the handling of sewage and waste-water, both in economic and environmental terms. Innovation and technical excellence facilitate diverse installations. Waste water from residential and industrial areas as well as municipal installations are no problem to the **KRT**.

KRT pumps function reliably in transfer pumping stations and pressure drainage systems, in the transportation of unscreened sewage, surface water, drainage water and sludge. Also in industrial applications such as those in the steel, cellulose, paper, textile and food industries.

Corrosive and abrasive nature of municipal and industrial waste water demand the use of specific materials that will provide resistance. Carefully selected material combinations of Cast Iron & Stainless Steel for pump castings & hydraulic components ensure optimum protection for uninterrupted operation.



Range of models available



Pump with surface cooled motor



Pump with jacket cooled motor



Technical Specifications

| | |
|----------------------------------|-----------------|
| Impeller type | Non Clog |
| DN (mm) | up to 350 |
| Discharge (l/s) | up to 900 |
| Head (m) | up to 60 |
| Temperature of pumped media (°C) | up to 40°C |
| Free passage (mm) | up to 143 |
| Speed (1/min) | 1450 or 960 |
| Frequency (Hz) | 50 |
| Voltage (V) | 415 (-15% +10%) |
| Power rating (kW) | 11 to 165 |

KRT

Submersible Motor Pumps

Performance range

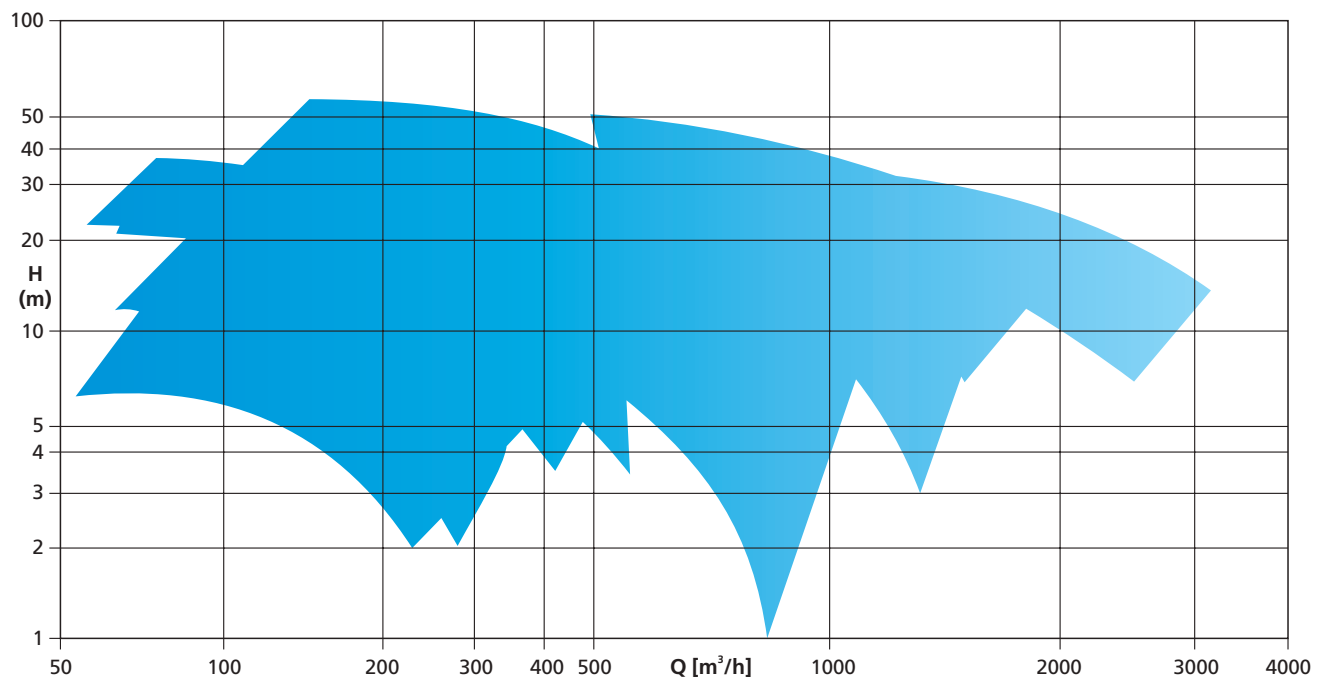

Type of installations

(Schematic)



Stationary guide wire installation



Stationary guide rail installation



Transportable

Unparalleled performance with security

KRT swallows a lot, but remains operationally secure in the toughest of conditions. An impeller design for every application when the duty demands it.



Totally sealed

A long cable gland with cable sheath and conductors cast in epoxy resin ensures a water tight seal.

Extended Life

Mechanical seal with silicon carbide faces, independent of the direction of rotation.

The E impeller (single vane)



Variety of hydraulics for optimum operation no matter what the liquid is

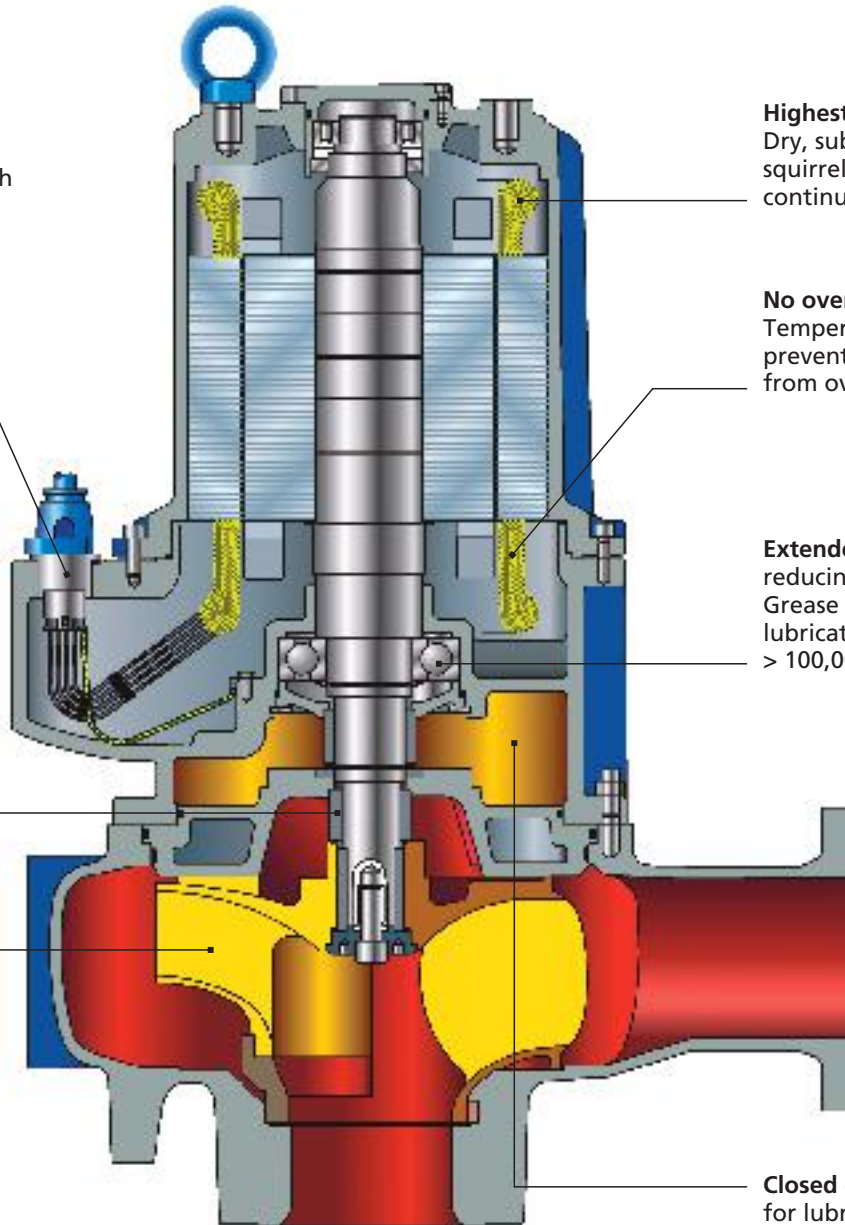

Highest Construction

Dry, submersible (IP68), squirrel cage motor, continuously rated.

No overheating

Temperature switches prevent the motor from overheating.

Extended maintenance intervals

reducing life cycle costs. Grease lubricated bearings lubricated for L10 bearing life > 100,000 hrs. optimum.

Closed oil chamber

for lubrication of the mechanical seal. No additional flushing or external liquid tank required. Thus reduction in investments and service cost. Oil change after 4000 operating hrs.

A submersible motor pump which “keeps cool”

The heart of the newly-developed KRT waste water pump. A uniquely designed closed jacket cooling system of the motor with clear liquid keeps the motor cool.

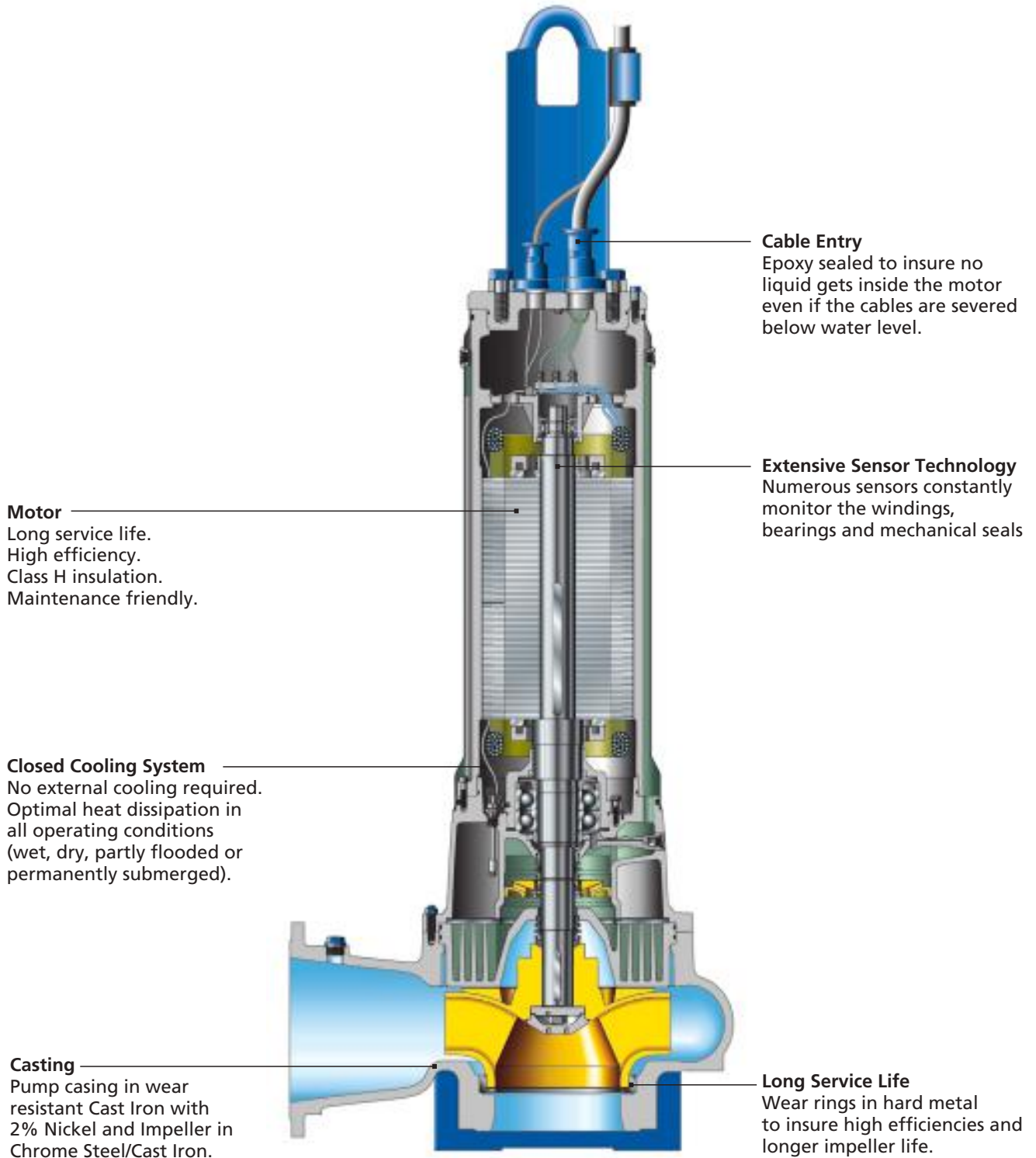

KSB Pumps and Valves - We are where you are

CONTACT US!

Manufacturing Plants :

Head Office & Pimpri :

Irrigation & Process Division
Mumbai-Pune Road, Pimpri,
Pune - 411 018.

Tel.: 020-2710 1000 Fax : 020-2742 6000

Chinchwad :

Power Projects Division
D-II Block, MIDC Chinchwad,
Pune - 411 019.

Tel.: 020-2740 9100 Fax : 020-2747 0890

Coimbatore :

Valves Division

151, Mettupalayam Road,
NSN Palayam Post,
Coimbatore - 641 031.
Tel.: 0422-246 8222, 246 8547-9
Fax : 0422-246 8232

Sinnar :

Water Pumps Division

Plot No. E-3 & E-4, MIDC Sinnar,
Nashik - 422 103.
Tel.: 02551-230252 / 53 / 55
Fax : 02551-230254

Vambori :

Foundry Division

Vambori, Ahmednagar - 413 704.
Tel.: 02426-272534, 272528, 272074
Fax : 02426-272043

Regd. Office :

126, Maker Chambers III, Nariman Point,
Mumbai - 400 021.
Tel.: 022-6658 8787 Fax : 022-6658 8788

Zonal Offices :

East :

30, Circus Avenue, 2nd Floor,
Kolkata - 700 017.
Tel.: 033-2287 0473, 2290 0117
Fax : 033-2287 0588

West :

126, Maker Chambers III, Nariman Point,
Mumbai - 400 021.
Tel.: 022-6658 8787 Fax : 022-6658 8788

North :

KSB House, A-96, Sector IV, NOIDA,
Dist. Gautam Budh Nagar - 201 301.
Tel.: 0120-254 1091-93, 254 1501-3
Fax : 0120-255 0567

South :

Guindy House, II Floor, 95, Anna Salai,
Chennai - 600 032.
Tel.: 044-2235 2571-2, 2235 5673
Fax : 044-2235 2749

Service Stations :

Chennai :

No. 4, (Old No. 18), Chakrapani Road,
Guindy, Chennai - 600 032.
Tel.: 044-2255 0704

Howrah :

142/1, Foreshore Rd., Ramkrishtipur,
Howrah - 711 101.
Tel.: 033-2638 2909 Fax : 033-2638 1547

NOIDA :

KSB House, A-96, Sector IV, NOIDA,
Dist. Gautam Budh Nagar - 201 301.
Tel.: 0120-254 1091-93, 254 1501-3
Fax : 0120-255 0567

Odhav :

Shed No. 22, Gujrat Vepari
Mahamandal, Odhav,
Ahmedabad - 382 410.
Tel.: 079-2290 0372

Branch Offices :

Ahmedabad :

Neel Kamal, Ashram Road, Opp. Sales
India, Ahmedabad - 380 009.
Tel.: 079-2754 0428, 2754 3427
Fax : 079-2754 2286

Aurangabad :

Plot no. P 204, Shivshankar Colony,
Near Bembde Hospital,
Aurangabad - 431 005.
Tel.: 0240-235 1440, 234 2447
Fax : 0240-235 1440

Bangalore :

191, 1st Floor, West of Chord Road,
2nd Stage, Bangalore 560 086.
Tel.: 080-2349 1806, 2349 3925
Fax : 080-2349 6036

Bareilly :

692-D, Janakpuri Awas Vikas Colony,
Bareilly - 243 122.
Tel.: 0581-230 4540 Fax : 0581-230 0748

Baroda :

4-B, Ramkrishna Chamber,
Productivity Road, Baroda - 390 005.
Tel.: 0265-233 0532, 233 3226
Fax : 0265-231 4693

Bhubaneswar :

N5/39, 1st Floor, IRC Village, Nayapalli,
Bhubaneswar - 751 013.
Tel.: 0674-255 8497, 255 3061
Fax : 0674-255 8499

Chandigarh :

S.C.O. 80-81, Sector 8-C, Madhya Marg,
Chandigarh - 160 008.
Tel.: 0172-254 9021, 254 4685
Fax : 0172-254 4685

Hubli :

Plot No. 25, Vaikunte Layout,
Near Nehru Nagar Circle,
Hubli - 580 030.
Tel.: 0836-223 2244 Fax : 0836-225 6579

Indore :

B-14, Ratlam Kothi, Indore - 452 001.
Tel.: 0731-252 9478, 252 9704
Fax : 0731-252 9704

Jaipur :

Anjali Chambers, 2nd Floor, Block C,
10, Rajbhawan Road, Civil Lines,
Jaipur - 302 001.
Tel.: 0141-222 4554, 222 4904
Fax : 0141-222 4904

Jamshedpur :

UG4, Gangotri House, Q Road,
Bistupur, Jamshedpur - 831 001.
Tel.: 0657-231 7129, 231 7130
Fax : 0657-231 7128

Lucknow :

309, Chintels House, 16, Station Road,
Lucknow - 226 001.
Tel.: 0522-263 5203, 263 5597
Fax : 0522-263 5597

Mumbai :

126, Maker Chambers III, Nariman Point,
Mumbai - 400 021.
Tel.: 022-6658 8787 Fax : 022-6658 8788

Nagpur :

203, Suryakiran Complex, Bajaj Nagar,
Nagpur - 440 010.
Tel.: 0712-223 6889, 222 9148
Fax : 0712-224 4184 (P.P.)

Pune :

1st Floor, Shree Gurukrupase Unnati,
C. T. S. No. 109/15, F. P. No. 54,
Prabhat Road Lane no. 14, Thorath
Colony, Income Tax Office Lane,
Pune - 411 004.
Tel.: 020-2543 1258/59/60
Fax : 020-2543 1262

Raipur :

House No. C/40, 1st Floor, Sector - 2,
Devendra Nagar, Raipur.
Tel.: 0771-406 2556, 258 3921
Fax : 0771-258 3921

Secunderabad :

D. No. 12-13-197, 198,
Flat No. 103 & 104, 1st Floor,
Pavani Anusuya Towers, Tarnaka,
Secunderabad - 500 017.
Tel.: 040-2700 1724, 2700 3696
Fax : 040-2700 1725



KSB PUMPS LIMITED

Mumbai-Pune Road, Pimpri, Pune 411 018.

Tel.: 020-2710 1000 Fax : 020-2742 6000 www.ksbindia.co.in