

FlexiROC T25 R Construction Edition

Surface drill rig for quarrying and construction

Folding boom hole diameter: 38–64 mm (1.5"–2.5")





Improve your speed and accuracy

The FlexiROC T25 R construction edition is a top hammer rig designed for faster drilling in a smaller hole range.

With Radio Remote Control, self-adjusting RPM and an extensive boom reach, the FlexiROC T25 R Construction Edition is versatile and extremely efficient. It is optimized for faster drilling in a smaller

hole range. Powerful enough to drill into very hard rock. Its compact size means it can easily be transported from job to job – allowing you to maximize on the availability of your investment.

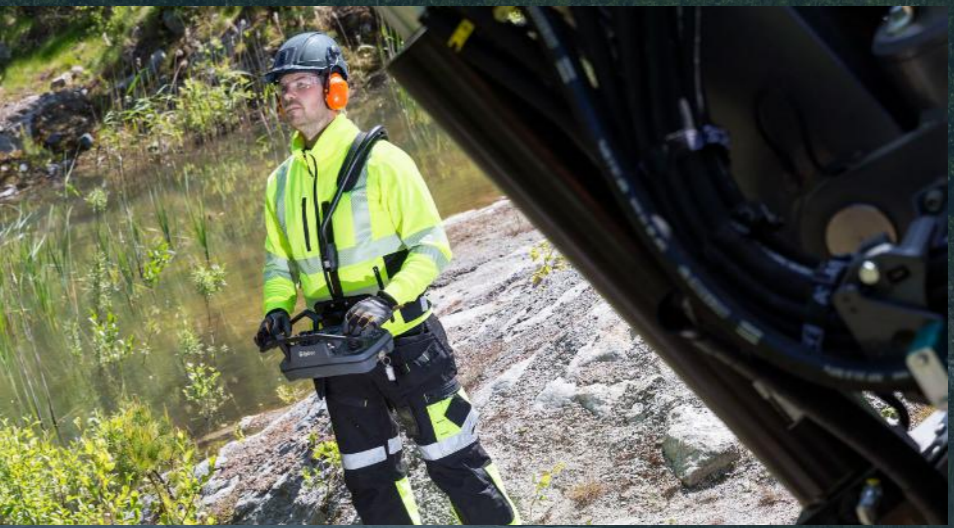

+ Main benefits

- Fast and accurate drilling** thanks to high frequency rock drill
- Excellent rig stability** means operator safety and productivity
- Extensive boom reach** means fewer set-ups

Availability at your fingertips

With great boom coverage that lets you drill more holes per set-up, the FlexiROC T25 R Construction Edition delivers true productivity. It is all in your hands with the 2.4 Ghz bluetooth Radio Remote Control.



+ Great reach and productivity

With its extensive boom reach, the FlexiROC T25 R Construction Edition offers contractors savings in both time and money. Boom reach of 5 300 mm (with RAS or RHS) through an 80° radius translates into more holes from fewer set-ups. This versatility makes the FlexiROC T25 R Construction Edition an ideal choice for demanding construction jobs, such as residential foundation and trench drilling.



+ Reliable and efficient

The FlexiROC T25 R Construction Edition meets stringent Tier 4 Final engine emissions standards. The Tier 3 engine option makes it possible to offer customers these well-proven, efficient top-hammer drill rigs over a greatly extended market and target group. Self-adjusting RPM ensures great efficiency and low diesel consumption. Thanks to the COP Logic system, the impact and drill feed pressure is automatically adjusted to ensure optimal performance and increased service life of rock drilling tools.



+ Safer than ever

The FlexiROC T25 R Construction Edition excels even in difficult terrain where its low center of gravity provides rugged mobility in all conditions. With Radio Remote Control as standard, the operator has full control over tramming and drilling while working at a safe distance from the rig – ideal for sites with limited access or unstable terrain. The FlexiROC T25 R Construction Edition can also be equipped with a hydraulic winch for secure anchoring on extreme slopes.



A comprehensive service offering

Even the best equipment needs to be serviced regularly to make sure it sustains peak performance. An Epiroc service solution offers peace of mind, maximizing availability and performance throughout the lifetime of your equipment. We focus on safety, productivity and reliability.

By combining genuine parts and an Epiroc service from our certified technicians, we safeguard your productivity – wherever you are.

Technical specifications

Main Components

- Crawler type two speed undercarriage with track oscillation system
- Cummins turbo charged diesel engine QSB4.5 Tier 4 Final
- Atlas Copco screw type compressor
- Folding boom system
- Hydraulic rock drills COP SC14
- Alternative Rod Handling Systems, RHS
- Dust Collection System, DCT
- Radio Remote Control system with integrated display

Hole range (recommended)

Hydraulic carousel type Rod Handling System (RHS) with 3.6 m (12') rods and 4.3 m (14') starter rod						
Rock drill	Metric	US	Threads	Boom type	Metric	US
COP SC14	Ø 38-64 mm	Ø 1.5"-2.5"	TC35E, R32E, T35E	Extra long folding boom	7.4 m (RAS) 14.8 m (RHS)	24' (RAS) 48' (RHS)

Hydraulic rock drill

Rock drill	Impact power		Impact rate	Weight approx		RPM, max	Torque, max		Hydraulic pressure, max	
COP SC14	14 kW	18.8 hp	80 Hz	81 kg	178.5 lb	200	825 Nm	608 lbf/ft	225 bar	3 260 psi
						250	1 070 Nm	789 lbf/ft	210 bar	3 046 psi

Engine

Cummins turbo charged, diesel engine, QSB4.5, Tier 4 Final	
Power rating at 2000 rpm	116 kW/155 hp
Electronic variable engine speed	870-2 030 rpm
Variable fan control	
Green saver – automatic low engine speed	
Cummins turbo charged, diesel engine, QSB4.5, Tier 3	
Power rating at 2000 rpm	116 kW/155 hp
Electronic variable engine speed	870-2 030 rpm
Variable fan control	
Green saver – automatic low engine speed	

Compressor

Atlas Copco OIS, screw compressor		
Working pressure, max	8.5 bar	123 psi
FAD, at normal working pressure	80 l/s	170 cfm

Electrical system

Voltage	24 V
Batteries	2 x 12 V, 185 Ah
Alternator	24 V, 70 Ah
Work lights, front	2 x 70 W halogen
Work lights, rear	2 x 70 W halogen
Work lights, feed	2 x 70 W
Display with diagnostics and settings	

Volumes

	Metric	US
Hydraulic oil tank	200 l	52.8 gal
Hydraulic system, total	250 l	66.0 gal
Compressor oil	20 l	5.3 gal
Diesel engine oil	11 l	2.9 gal
Diesel engine, fuel tank	270 l	71.3 gal
Traction gear	3 l	0.8 gal
Lubrication tank (ECL)	10 l	2.6 gal
AdBlue (Tier 4 final)	15 l	4.0 gal

Hydraulic system

Anti-jamming		
Rotation Pressure Control feed RPC-F		
Damper Pressure Control - impact DPC-I		
Return and drainage filters F (filtration rate)	16 µm absolute	
Hydraulic oil cooler max ambient temperature	50°C	122°F

Feed

Extra long folding boom*	Metric	US
Total length	6 000 mm	236"
Travel length	4 070 mm	160"
Feed extension	1 000 mm	39"
Feed rate, max	0.9 m/s	3 ft/min
Feed force, max	12 kN	2 697 lbf
Tractive pull, max	15 kN	3 372 lbf

* Hydraulic aluminium cylinder feed with hose guide and single drill steel support with moveable lower guide/dust hood.

Dust collector DCT

	Metric	US
Filter area	8 m ²	86 sq.ft
Suction capacity at 500 mm wg	580 l/s	1 228 cfm
Suction hose diameter	102/127 mm	4/5"
Cleaning air pressure, max	75 bar	109 psi
Cleaning air consumption at 7 bar	15 l/pulse	0.53 cu.ft./pulse
Filter cleaning while drilling		
2 pcs of filter elements		

Technical specifications

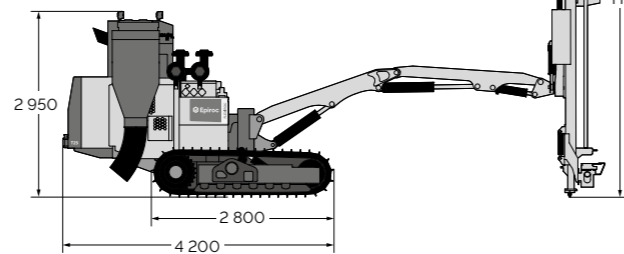
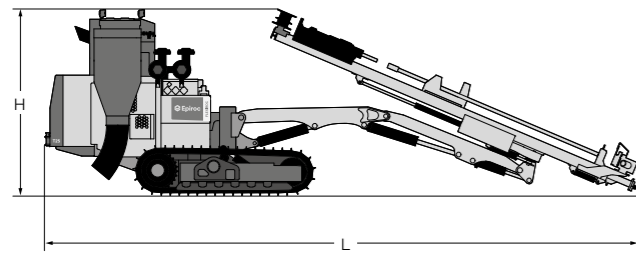

Height and length

Extra long folding boom		
Height (H)	2 950 mm	116"
Length (L)	9 200 mm	362"

Feed height (H)

	Metric	US
Extra long folding boom	6 200 mm	244"

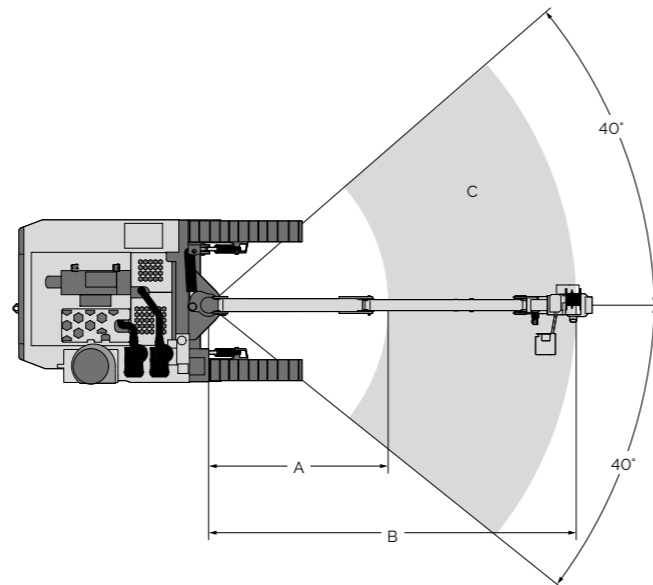
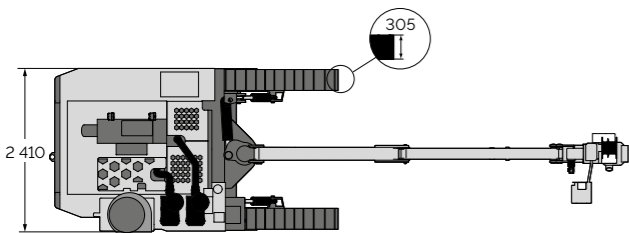

Weight

Standard unit excluding all options and drill steel	Metric	US
	9 900 kg	21 825 lb

Horizontal reach and coverage area

	A	B	C
Extra long folding boom	2 600 mm	5 300 mm	15 m ²

Technical specifications

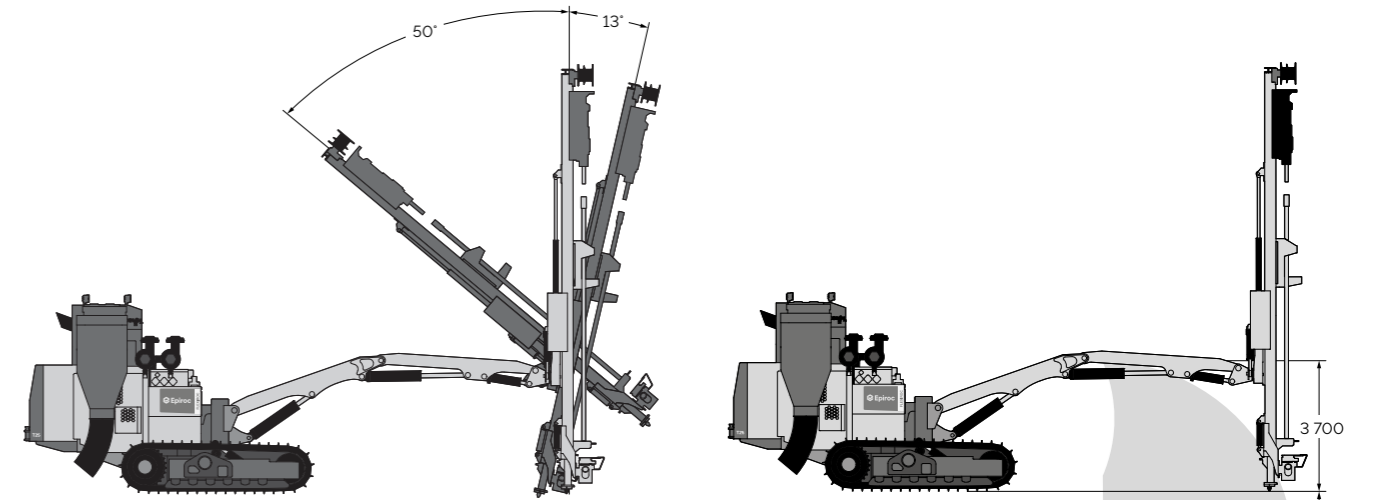

Dumping angles (extra long folding boom)

Vertical reach (extra long folding boom)

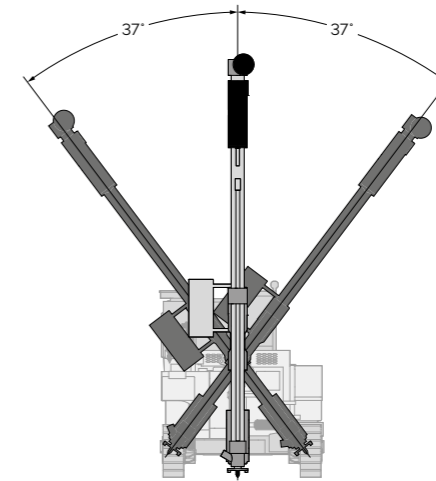

Normal position range in downwards directed drilling (extra long folding boom)

Selection of options

Carrier

- Hydraulic support leg
- Hydraulic winch
- Cold start kit (-25 °C)
- Diesel engine preheater
- Extra LED work lights

Feed

- Silence kit for reduced noise levels
- Jaw set for TC35E/R32E/T35E sleeves for RAS arm
- Rod rack with a capacity of three 3 660 mm (12') rods (option on)
- Rod Handling System with a capacity of three 3 660 mm (12') rods for extra long folding boom

Hole measuring systems

- Mechanical hole inclination instrument – ROCANGIE
- Electronic hole inclination instrument with depth/sight/laser and auto feed alignment

GPS aiming device

Dust control

- Rubber disc for dust collector hood
- Rubber skirt for dust collector hood
- Water mist system including tank

Lube oil and lube system

- Thread greasing devise, type ECG (with oil)
- Central lubrication system
- Tropical hydraulic oil, ISO VG 68
- Artic hydraulic oil, ISO VG 32
- Environmentally conformed hydraulic oil, ISO VG 46
- ECL collection system

Delivered equipment, not mounted

- Gas charging equipment for rock drill
- Conversion kit R32/T35/TC35

United in performance. Inspired by innovation.

Performance unites us, innovation inspires us, and commitment drives us to keep moving forward. Count on Epiroc to deliver the solutions you need to succeed today and the technology to lead tomorrow.
epiroc.com

