

# FlexiROC T20 R

A drill rig for surface- and underground construction

Hole diameter: 38-64 mm (1.5" - 2.5")



# Multi-purpose without compromise

The FlexiROC T20 R (MK II) is the construction contractor's new best friend. The pure drilling power of the 14 kW rock drill is key.

Features such as Radio Remote Control (RRC), COP SC14 rock drill and flexible drilling angles make the FlexiROC T20 R class-leader. It makes even the toughest operations look easy. Its compact size

means it can be transported swiftly from Job to Job. The FlexiROC T20 R is the most effective drill rig on the market when it comes to application versatility and drilling performance.

## ⊕ Main benefits

**Application versatility** thanks to the COP SC14 rock drill

**Extensive boom reach** means fewer set-ups

**Optimized for small spaces** thanks to three different feed lengths

# Performance and application versatility

The FlexiROC T20R is a class-leader. It has great coverage, hydraulic rollover and is equipped with the COP SC14 rock drill. This makes it ideal for many applications, both on the surface and underground



## + Great coverage area and productivity

With its extensive boom reach, the FlexiROC T20 R saves both time and money. A boom reach of 3 500 mm through a 90° radius translates into more holes from fewer set-ups. This versatility makes the FlexiROC T20 R the best choice for demanding construction jobs, such as foundation drilling, trenching and different tunneling operations.



## + Hydraulic rollover

Most drill rigs can place holes in the ground, but the FlexiROC T20 R does not stop there. It can perform 360° drilling in all directions, sideways, upwards and horizontal face drilling. This makes the drill rig perfectly suited for operations both on the surface and underground. It is all made possible with the rollover, available as hydraulic or manual.



## + Cylinder feed and COP SC14

The high frequency rock drill, COP SC14, mounted on the well proven Epiroc cylinder feed BMH 2000, makes for outstanding drilling performance. The smooth feed action keeps sleeve temperatures to a minimum which means good service life of the rock drilling tools, even with high impact pressure.



## A comprehensive service offering

Even the best equipment needs to be serviced regularly to make sure it sustains peak performance. An Epiroc service solution offers peace of mind, maximizing availability and performance throughout the lifetime of your equipment. We focus on safety, productivity and reliability.

By combining genuine parts and an Epiroc service from our certified technicians, we safeguard your productivity – wherever you are.

## Technical specifications

### Main Components

- Hydraulic rock drill, COP SC14
- BMH 2000 cylinder feed
- Full Radio Remote Control of all functions
- Atlas Copco OIS H03 screw compressor
- Hydraulic rollover, 190° + 190°
- Cummins turbo charged diesel engine, QSB3.3 Tier 3 (stage IIIA) or Tier 4 interim
- Hydraulic drill rod support
- 4-wheel drive with differential locking system

### Hole range (recommended)

Feed type, underground drilling (with hole length)	Metric	US	Threads	Metric			US		
				Std.	RAS (option)		Std.	RAS (option)	
				1 drill rod	2 drill rods	2+ drill rods	1 drill rod	2 drill rods	2+ drill rods
With 8' feed	Ø 38-64 mm	Ø 1.5"-2.5"	SR32, R32, TC35, T35	2.2 m	4.0 m	12 m'	7.2'	13.1'	39.4'
With 10' feed				2.9 m	5.3 m		9.5'	17.4'	
With 12' feed				3.4 m	6.5 m		11.1'	21.3'	
Feed type, surface drilling (with hole length)									
With 8' feed	Ø 38-64 mm	Ø 1.5"-2.5"	SR32, R32, TC35, T35	2.1 m	3.9 m	12 m'	6.9'	12.8'	39.4'
With 10' feed				2.8 m	5.2 m		9.2'	17.1'	
With 12' feed				3.3 m	6.4 m		10.8'	20.1'	

\* Requires manually loading additional drill rods into the RAS.

### Engine

Cummins turbo charged, diesel engine, QSB3.3, Tier 3 (stage IIIA)/Tier 4 interim	
Power rating at 2 400 rpm	82 kW/110 hp

### Compressor

Atlas Copco OIS H03/Gardner Denver Enduro 6+ Tier 3 (stage IIIA)		Metric	US
Working pressure, max		12 bar	174 psi
FAD, at normal working pressure		50 L/s	106 cfm

### Hydraulic rock drill

Rock drill	Boom type	Impact power	Hydraulic pressure, max	Impact rate	RPM, max	Torque, max	Weight approx				
COP SC14	Folding boom	14 kW	19 hp	210 bar	3 045 psi	80 Hz	250	470 Nm	206 lbf/ft	75 kg	165 lb

### Feed

	With 8' feed		With 10' feed		With 12' feed	
	Metric	US	Metric	US	Metric	US
Total length	4 020 mm	158.3'	4 620 mm	181.9'	5 220 mm	205.5'
Travel length	2 390 mm	94.1'	2 990 mm	117.7'	3 590 mm	141.3'
Feed extension	600 mm	23.6'	1 000 mm	39.4'	1 000 mm	39.4'
Feed rate, max	0.5 m/s	98 ft/min	0.5 m/s	98 ft/min	0.5 m/s	98 ft/min
Feed force, max	16 kN	3 597 lbf	16 kN	3 597 lbf	16 kN	3 597 lbf
Tractive pull, max	20 kN	4 400 lbf	20 kN	4 400 lbf	20 kN	4 400 lbf

### Electrical system

Voltage	24 V
Batteries	2 x 12 V, 100 Ah
Alternator	24 V, 55 Ah
Work lights, front	2 x 40 W LED + 2 x 70 W halogen
Work lights, rear	1 x 40 W + 2 x 21 W LED
Work lights, feed	2 x 40 W LED
Reverse buzzer	

### Hydraulic system

Hydraulic oil cooler max ambient temperature	50°C	122°F
Return and drainage filters (filtration rate)	10 µm absolute	
Anti-jamming		
Damper Pressure Control - impact DPC-I		
Rotation Pressure Control - feed RPC-F		

### Volumes

	Metric	US
Hydraulic oil tank	60 l	16.0 gal
Hydraulic system, total	120 l	32.0 gal
Compressor oil	9 l	2.4 gal
Diesel engine oil	8.5 l	2.2 gal
Diesel engine, fuel tank	140 l	37.0 gal
Lubrication tank (ECL)	6 l	1.6 gal

### Dust collector DCT

	Metric	US
Filter area	8 m²	86 sq.ft
Suction capacity at 500 mm wg	580 L/s	1 228 cfm
Suction hose diam	102/127 mm	4/5"
Cleaning air pressure, max	7.5 bar	109 psi
Cleaning air consumption @ 7 bar	15 L/pulse	0.53 cu.ft/pulse
Filter cleaning while drilling		
2 pcs of filter elements		

# Technical specifications

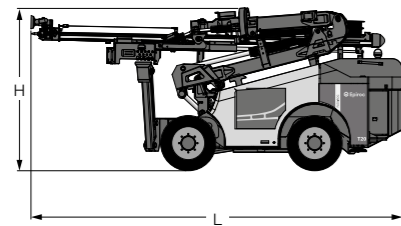

Dimensions for 12' feed

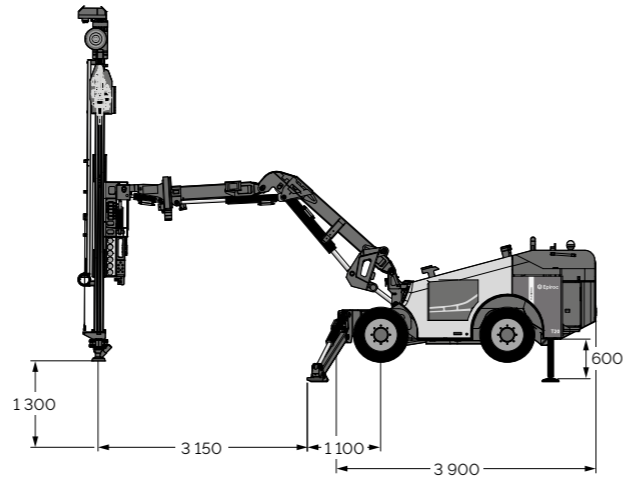

## Transport dimensions

	Metric	US
Height (H)	2 600 mm	102.4'
Length (L)	5 700 mm	224.4'
Width (W)	1 880 mm	74.0'
Weight (12' feed standard unit)	5 600 kg	12 345 lb

## Feed height

	Metric	US
8' feed	4 020 mm	158.3'
10' feed	4 620 mm	181.9'
12' feed	5 220 mm	205.5'

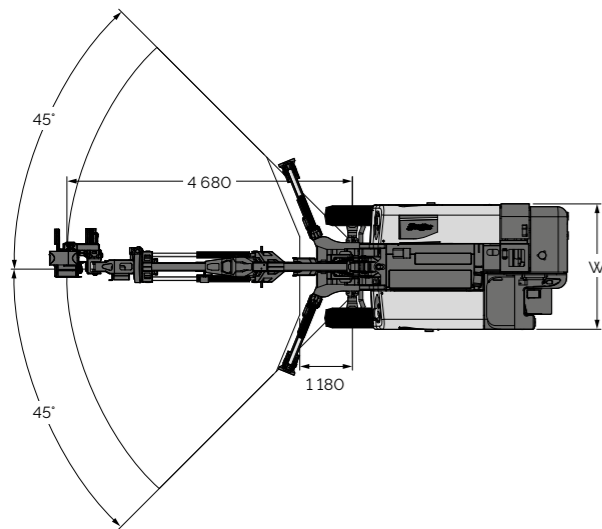

Horizontal reach (mm)

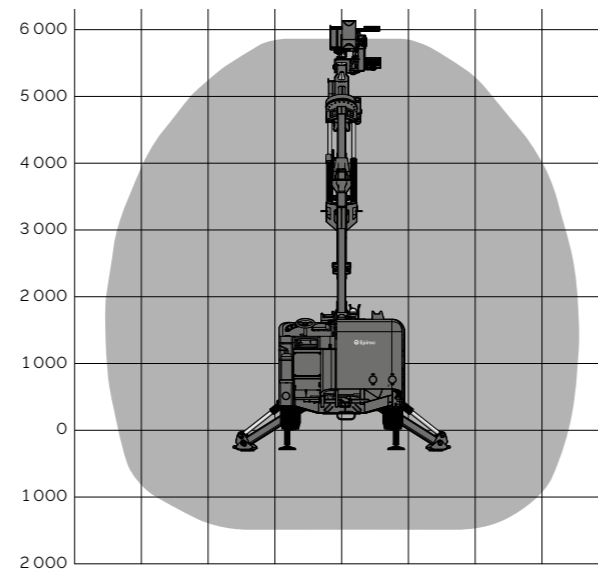

Horizontal drilling forwards with hydraulic rollover

# Technical specifications

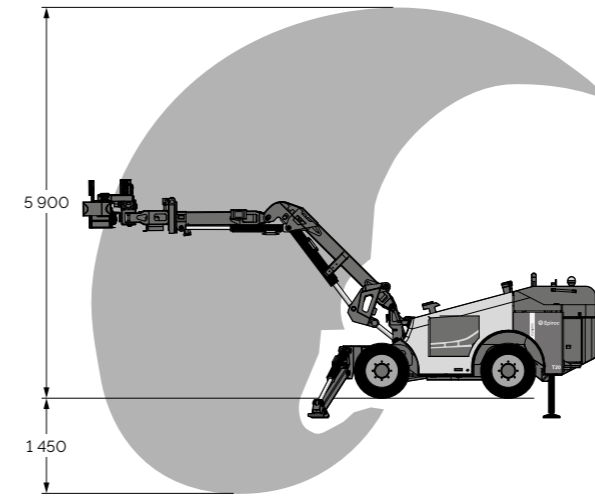

Horizontal drilling sideways (mm)

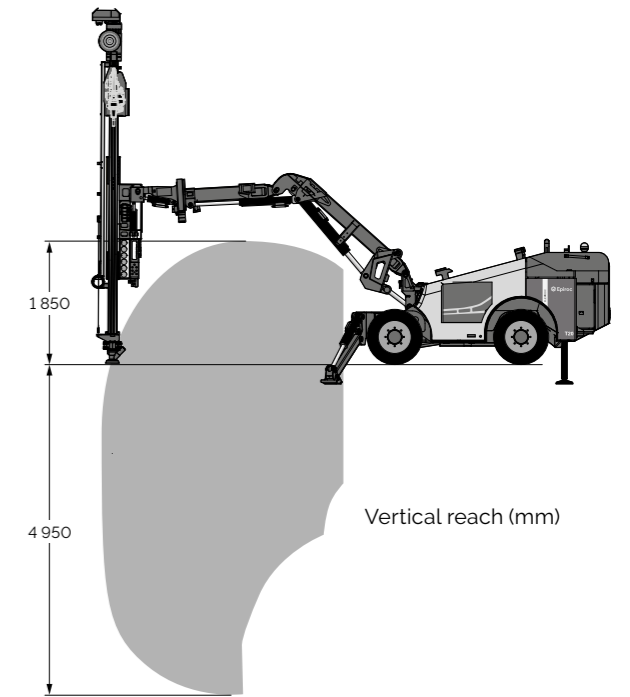

Vertical reach (mm)

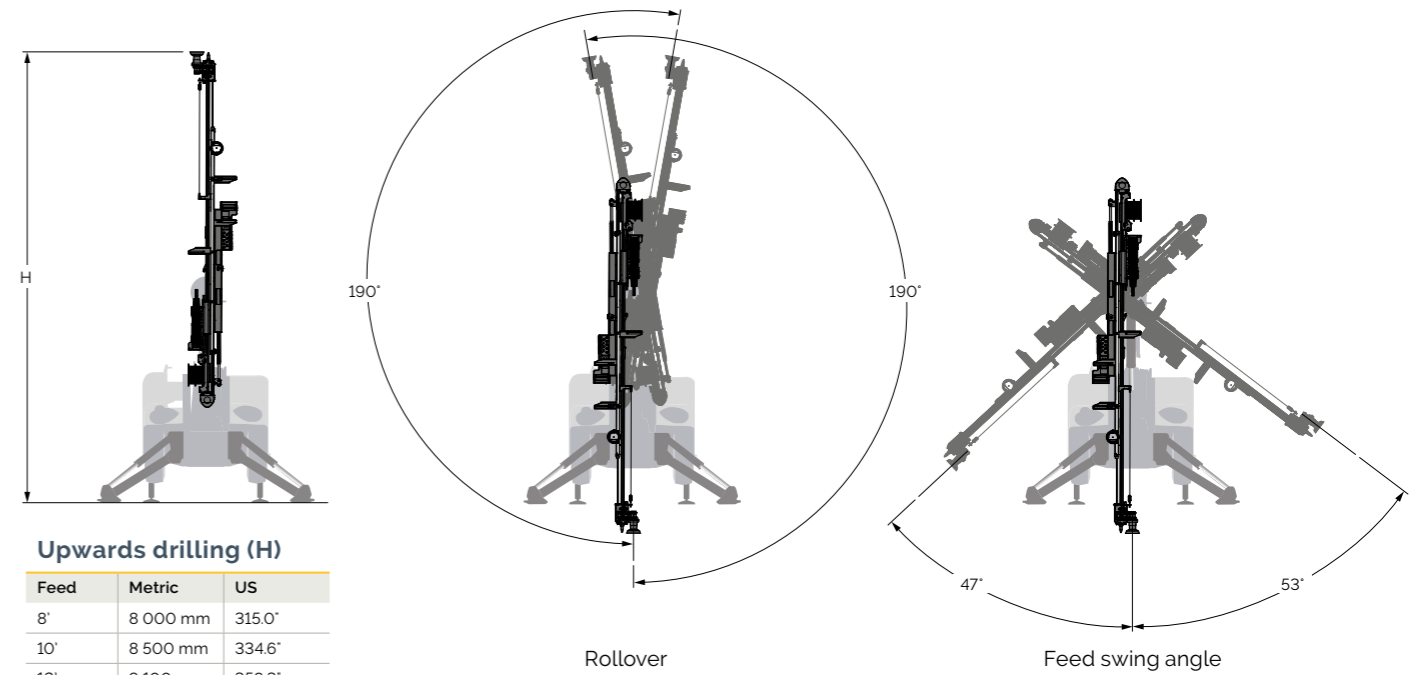

## Upwards drilling (H)

Feed	Metric	US
8'	8 000 mm	315.0'
10'	8 500 mm	334.6'
12'	9 100 mm	358.3'

## Optional equipment

### Carrier

- Water flushing kit with water pump
- Hydraulic winch
- Diesel engine pre heater
- Electric refilling pump
- Hydraulic AUX outlet

### Dust control

- Water mist system

### Feed

- Available with 8', 10' and 12' feed
- Rod Adding System (RAS)

### Hole measuring systems

- Hole length instrument

### Lube oil and lube system

- ECL collection system

### Delivered equipment, not mounted

- Gas charging equipment for rock drill
- Conversion kit R32
- Conversion kit T35/TC35
- Chains for tires

# United in performance. Inspired by innovation.

Performance unites us, innovation inspires us, and commitment drives us to keep moving forward. Count on Epiroc to deliver the solutions you need to succeed today and the technology to lead tomorrow.  
**[epiroc.com](https://www.epiroc.com)**

