

FlexiROC T15 R

Surface drill rig for quarrying and construction

Hole diameter: 27-51 mm (1"-2")



A yellow and black Epiroc FlexiROC T15 R drill rig is shown in a rocky, outdoor environment. The rig is a compact, self-propelled, four-wheel drive machine with a long, horizontal boom. The boom is equipped with a 360-degree mechanical roll-over feed beam and a re-pinning mechanism. The rig has a control panel on the side and a large, heavy-duty tire with a chain drive. The background shows a rocky terrain with some trees in the distance.

Productivity in a small package

When small holes mean big business, the FlexiROC T15 R drill rig is your best friend.

The FlexiROC T15 R is a compact, self-propelled, four-wheel drive drill rig that weighs in at 3 570 kg. It has a 360 degrees mechanical roll-over feed beam and the entire re-pinning operation takes only 180 seconds. With a long, horizontal reach that can drill 27–51 mm (1"–2") holes where you want them, this versatile machine is the perfect choice for demanding small construction jobs, dimension stone industry, and unique applications such as self-drilling anchors and boulder blasting.

⊕ Main benefits

Large boom coverage makes the rig suitable for a variety of construction applications

Advanced rock drill design for great Free Air Delivery (FAD) capacity

Excellent tramming stability for go-any-where accessibility

Productivity just got easier

This easy-to-transport hydraulic surface drill rig delivers high performance on demanding sites. FlexiROC T15 R has great boom coverage, flexible drilling capacity and excellent tramming stability.



+ Quick and safe drilling in rough terrains

The innovative design of the FlexiROC T15 R drill rig makes it a stable partner for fast, steady movement even in rough terrain. This drill rig can be equipped with a hydraulic, variable-force winch for extreme working conditions that call for secure anchoring when tramming. For even safer movement, its specially designed front support legs can also assist in downhill tramming.



+ Rugged and economical

FlexiROC T15 R has the same Epiroc quality folding boom and durable aluminum feed as its larger cousins in the FlexiROC-series. Thanks to the Tier 4 Final/Stage 5 engine, the FlexiROC T15 R meets the exhaust emission standards for EU and US. The engine RPM can also be adjusted via remote control to minimize fuel consumption.



+ Smooth drilling

FlexiROC T15 R drill rig is equipped with a drill control system that automatically adjusts impact and feed speed in proportion to rotation torque. This means high productivity and smooth drilling even in soft, cracked formations. The rock drill control system increases drill rod life by decreasing stress through proportional control of vital drill parameters.



A comprehensive service offering

Even the best equipment needs to be serviced regularly to make sure it sustains peak performance. An Epiroc service solution offers peace of mind, maximizing availability and performance throughout the lifetime of your equipment. We focus on safety, productivity and reliability.

By combining genuine parts and an Epiroc service from our certified technicians, we safeguard your productivity – wherever you are.

Technical specifications

Main components

- Hydraulic rock drill, COP 1020 series
- Caterpillar 2.2 TA Tier 4 Final/Stage 5 diesel engine
- On-board Atlas Copco screw compressor, C55
- Aluminium profile feed beam
- Carrier with rubber tires
- Rod rack on carrier
- Full Remote Remote Control for all boom, drilling and tramming functions
- Support legs
- Air outlet with claw coupling
- Manual re-pinning of the feed for 360° swing angle coverage
- Service hand lights inside canopy, one piece with two connection points

Hole range (recommended)

Rock drill	Threads	Maximum hole length		Drill diameter		Drill rod length	
		Metric	US	Metric	US	Metric	US
COP 1022	HEX 22x108	9 m	29.5'	Ø 27-45 mm	Ø 1"-1.75"	3 660 mm	144.1'
COP 1028	R28, SR28, R32, SR32	9 m	29.5'	Ø 33-51 mm	Ø 1.25"-2"	3 660 mm	144.1'

Hydraulic rock drill

Rock drill	Impact power		Hydraulic pressure, max		Impact rate	Torque at shank, max		Weight approx	
COP 1022	4.5 kW	6 hp	150 bar	2 175 psi	70 Hz	126 Nm	93 lbf/ft	50 kg	110 lb
COP 1028	5.5 kW	7.4 hp	185 bar	2 683 psi	50 Hz	205 Nm	151 lbf/ft	51 kg	112 lb

Engine

Caterpillar diesel engine	
C2.2 TA Tier 4 Final/Stage 5 (EU/US cert.)	55 kW/74 hp (at 2 400 rpm)

Electrical system

Voltage	12 V (24 V, Tier 3 engine)
Batteries	2 x 12 V, 77 Ah
Alternator	14.4 V, 85 A (24 V, 60 Ah)
Work lights, on the carrier	3 x LED
Work lights, on the feed	2 x LED
Sound alarm and flashing light	

Hydraulic system

Hydraulic oil cooler max ambient temp.	40°C/104°F
Return & drainage filters (filtration rate)	16 µm absolute
Manual hydraulic oil filling pump	

Tramming

	Metric	US
Tramming speed, max	3.5 km/h	2.2 mile/h
Traction force (low/high gear)	20 kN	4 500 lbf
Ground clearance	230 mm	9"
Tramming angles		
Downward/upward max. without winch		20°/20°
Downward/upward max. with winch		30°/20°
Laterally, max (left/right)		20°/20°

Noise levels

Low idle	92 dB(A)
Idle	98 dB(A)
Max. engine speed	106 dB(A)
Drilling	123 dB(A)
Guaranteed sound power level (drilling)	129 dB(A)

Compressor

Atlas Copco C55 C106 GD, screw compressor	Metric	US
Working pressure, max	8.5 bar	123 psi
FAD, at normal working pressure	23 L/s	49 cfm
Air outlet for grinder		

Feed

Hydraulic chain feed	Metric	US
Feed extension	600 mm	23.6'
Feed rate, max	15 m/s	295 ft/min
Feed force, max	4 kN	899 lbf
Tractive pull, max	6 kN	1 348 lbf
Total length	4 988 mm	196.4'
Travel length	3 555 mm	140'

Dust collector DCT T15

	Metric	US
Filter area	4 m ²	43 sq.ft
Suction capacity at 500 mm wg	300 L/s	635 cfm
Suction hose diam	102 mm	4"
Cleaning air pressure, max	8.5 bar	123 psi
Cleaning air consumption	10 L/pulse	0.35 cu.ft./pulse
Number of filter elements	8 pcs	

Volumes

	Metric	US
Hydraulic oil tank	60/70 l	16/18.5 gal
Hydraulic system, total	90/100 l	24/26 gal
Compressor oil	8 l	2.1 gal
Diesel engine oil	10 l	2.6 gal
Diesel engine, cooling system	15 l	3.2 gal
Diesel engine, fuel tank	67 l	18.5 gal
Lubrication tank (ECL)	5 l	1.3 gal

Technical specifications

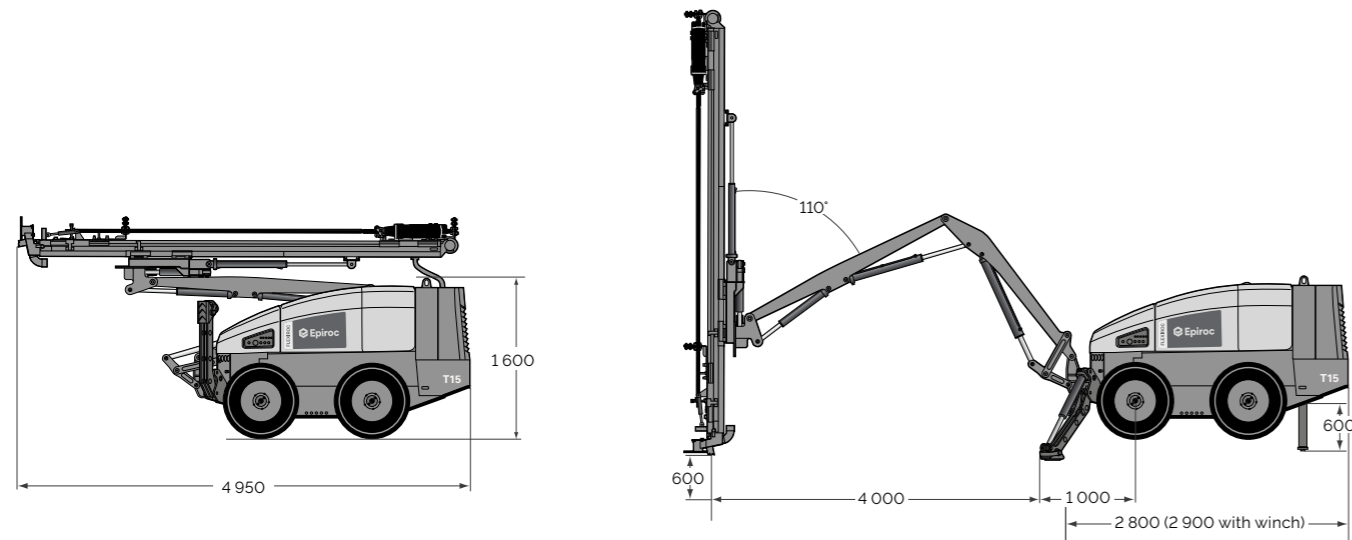

Transport dimensions

Feed dumped	Metric	US
Height	2 250 mm	88.6'
Width	1 770 mm	69.7'
Length	4 950 mm	194.9'

Weight

	Metric	US
Standard unit excluding all options and drill rod	3 570 kg	7 870 lb

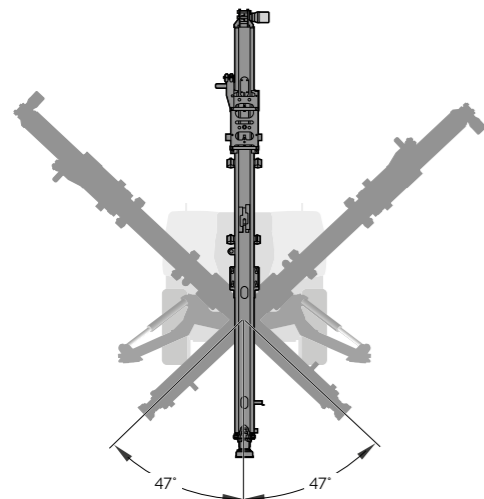

Alternative A: Normal position

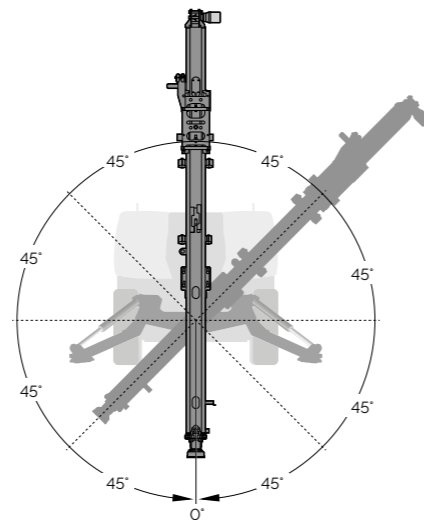

Alternative B: Re-pinning in steps of 45 degrees enabling drilling in 360 degrees

Technical specifications

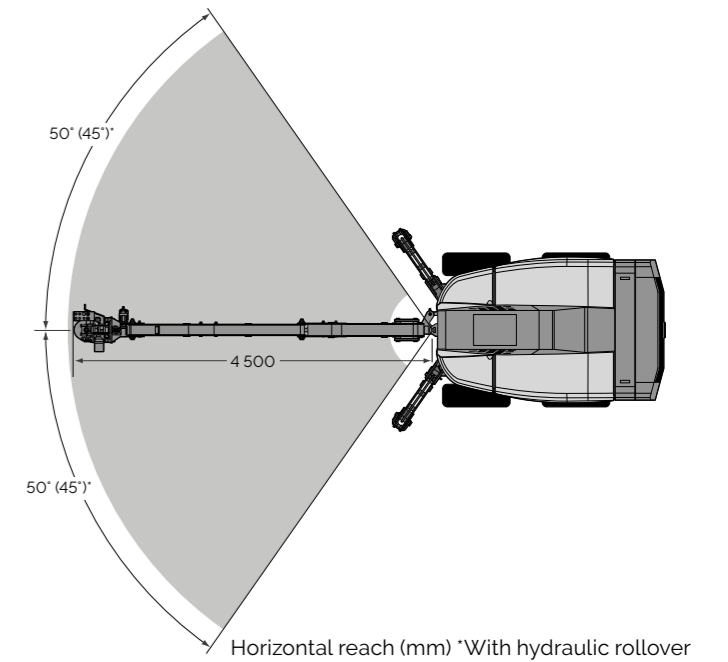
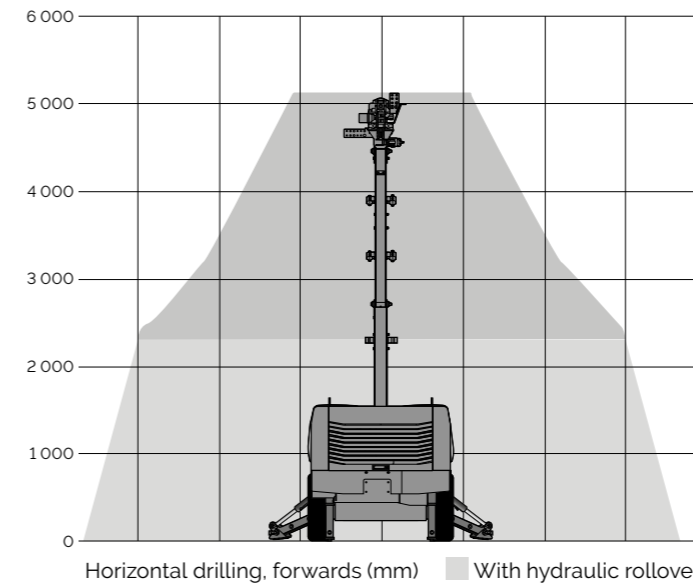
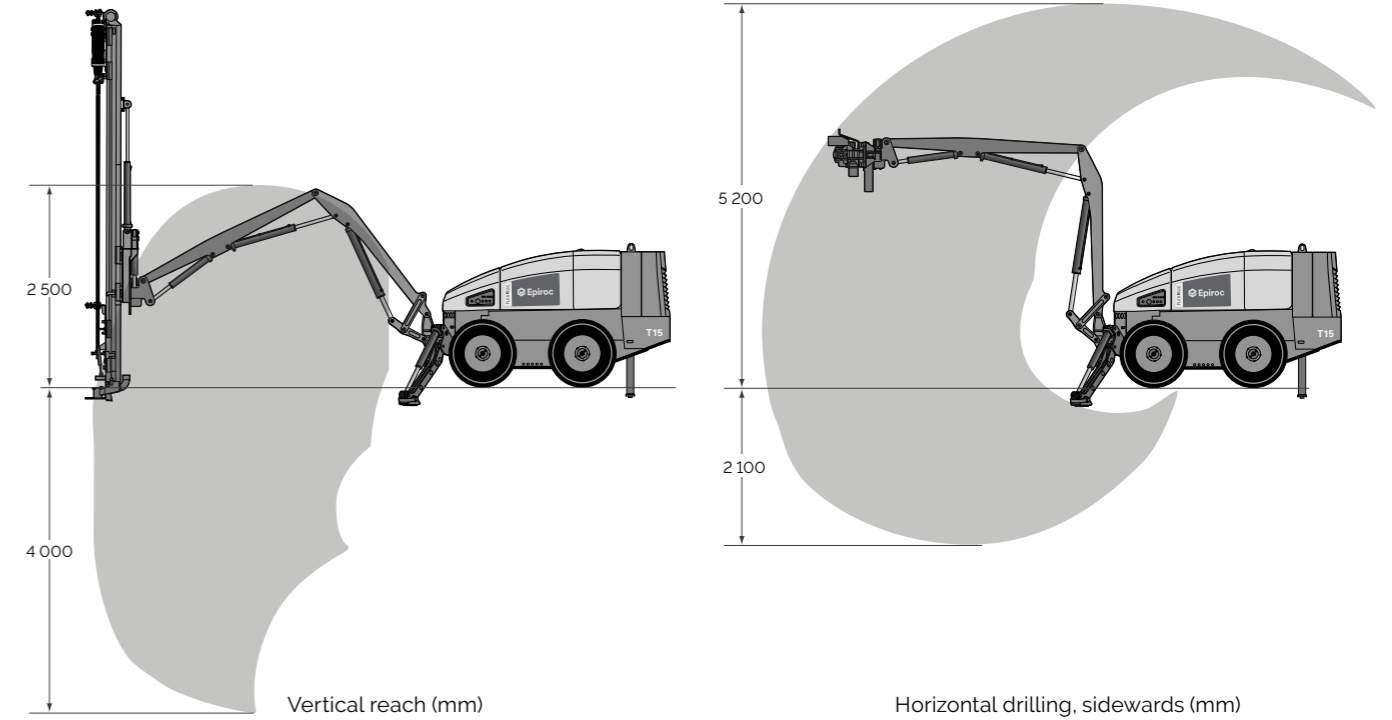

Selection of options

Carrier

- Instrument panel light.
- Diesel engine heater.
- Hydraulic winch including wire with towing eye and wire guides.
- Electric refuelling pump.
- Chain tracks mounted on wheels.
- Hydraulic outlet for auxiliary equipment with electrical on/off.
- Operators display for rock drill control and diagnostic.

Feed

- Hydraulic drill rod support.
- Rapid feed pullback stop sensor.
- Hydraulic rollover.

Lube oil, lube system and water mist system

- Artic hydraulic oil, VG 32.
- Tropical hydraulic oil, VG 68.
- Biological hydraulic oil, VG 46.

Hole measuring systems

- Mechanical hole inclination instrument, ROC-Angle.

Delivered equipment, not mounted

- Gas charging equipment for rock drill.
- First 50 hours service kit.
- 1 set of extra manuals.
- Lubrication kit (grease and COP oil).



9868 0026 01a, 2020-10 Orebro, Sweden. Legal Notice © Copyright 2020, Epiroc Rock Drills AB, Orebro, Sweden. All product names in this publication are trademarks of Epiroc. Any unauthorized use or copying of the contents or any part thereof is prohibited. Illustrations and photos may show equipment, with optional extras. No warranty is made regarding specifications or otherwise. Specifications and equipment are subject to change without notice. Consult your Epiroc Customer Center for specific information.

United in performance. Inspired by innovation.

Performance unites us, innovation inspires us, and commitment drives us to keep moving forward. Count on Epiroc to deliver the solutions you need to succeed today and the technology to lead tomorrow.
[epiroc.com](https://www.epiroc.com)

