



Ball Valve
Two-piece construction
Floating / Trunnion
mounted ball
Full Bore / Regular Bore
Flanged Ends

1/2"-16" (15-400mm)
Class 150, 300
Design as per BS EN ISO 17292

Applications

- Process and general industry
- For water, steam, gas, oil and other media
- Other applications on request

Operating data

- Maximum allowable pressure 740 psi (51.1 bar)
- Maximum allowable temperature 392°F (200°C)
- Pressure/Temperature rating as per ASME B 16.34 or seat Pressure/temperature rating, whichever is less

Body Materials

- ASTM A 216 WCB Carbon Steel
- ASTM A 351 CF8 Type 304 Stainless Steel
- ASTM A 351 CF8M Type 316 Stainless Steel

Ball Materials

- ASTM A 351 CF8 Type 304 Stainless Steel
- ASTM A 351 CF8M Type 316 Stainless Steel

Seat Material

- PTFE

Design

- As per BS EN ISO 17292
- Pressure, Temperature rating as per ASME B 16.34 (within the limits of the provided seat material).
- Testing as per BS EN 12266-1 / API 598
- Blowout proof stem
- ISO 5211 Mounting pad
- Antistatic device
- Floating Ball : 1/2" to 6"
- Trunnion Mounted Ball : 8" to 16"

Variants on Request

- Gear execution
- Pneumatic actuator
- Electric actuator
- Fire safe configuration
- Locking device
- Extended stem for insulation
- Alternate seats in RPTFE, PTFE + Graphite, Peek, Nylon, Acetal Resin

Remarks :

Type Series Booklets
ECOLINE BLC-S 400-800
ECOLINE BLD-S 150-300
ECOLINE BLN-S 150-300
Operating Instructions

On all enquiries/orders please specify :

1. Valve type
2. ANSI pressure class
3. Size
4. Design pressure
5. Design temperature
6. Operating temperature
7. Differential pressure-shut off
8. Flow medium
9. Material of construction
10. Variants
11. Type Series Booklet no.
12. Valve data sheet (if applicable)

When ordering spares, indicate valve serial number.

Product features to our customer benefit

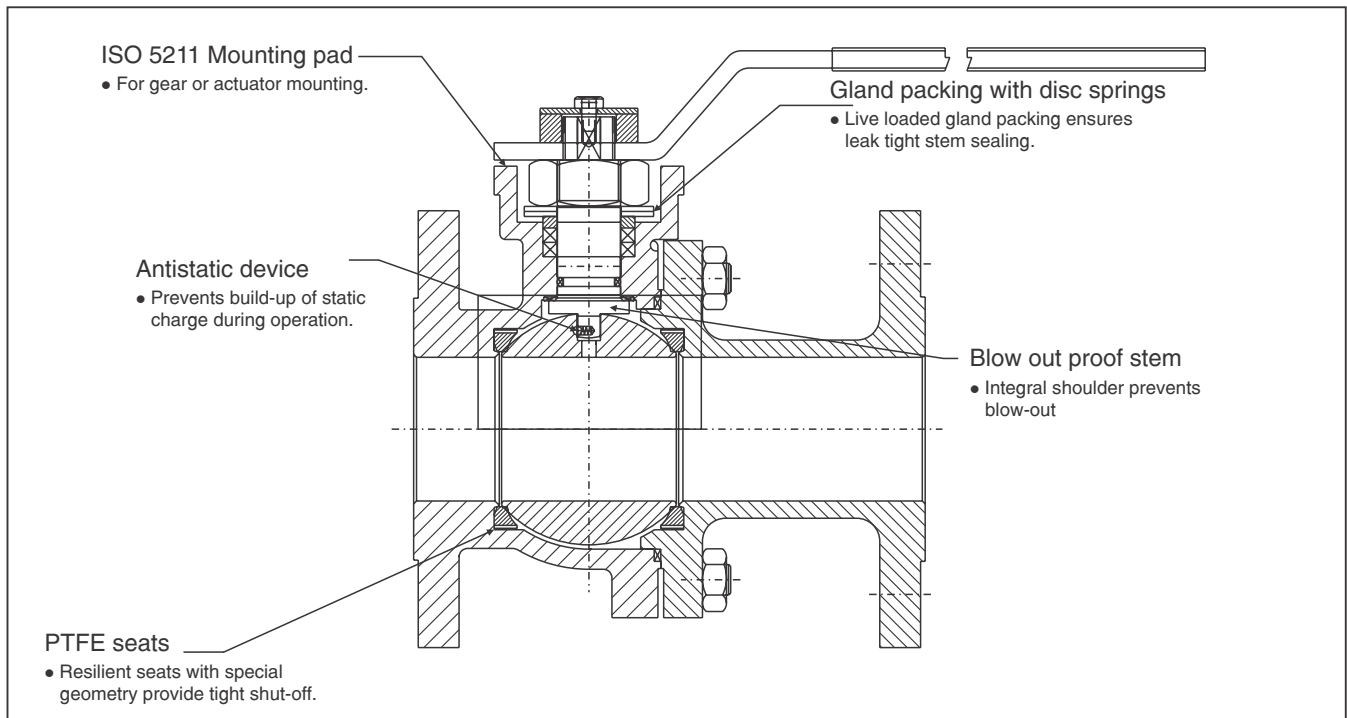

Blow-out proof stem

“KSB” valves are of bottom entry stem design. The stem is inserted from inside the body and stem collar sits on the integral land provided in the body. Higher the line pressure, tighter will be the seal. This is a safety feature and it does not allow stem to come out and eliminates possible accidents.

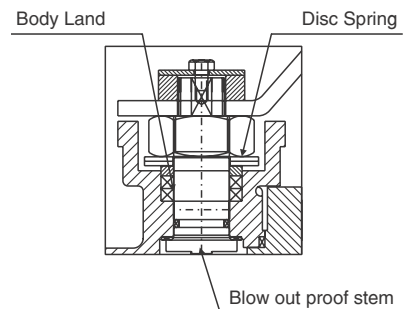

Stem Seal with Belleville Washer

Stem packing consist of stem seal and gland packing rings as per design requirement which ensures leak tight stem sealing. Disc springs are pre-compressed and ensure that gland packing load is maintained on the stuffing box. This compensates the varying forces on the sealing gland resulting from changes in pressure and temperature. This also gives excellent thermal conductivity

Floating Ball

In closed position, when the line pressure is acting on the upstream side ball, it moves/floats freely towards the down stream side seat giving effective tight sealing. In the open position the fluid gets trapped in the body cavity and builds up the pressure. Hole provided on the ball prevents this and ensures no damage to the seats.

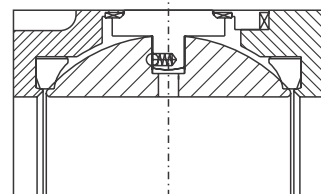

Antistatic Feature

During operation, constant rubbings of the ball and PTFE seats may generate static electricity which can lead to fire hazard especially when the service medium is of inflammable nature. A spring and a small ball fitted between ball and stem ensures electrical continuity. For smaller size valves below 40 mm, carbon filled PTFE stem seals provides/meets this continuity.

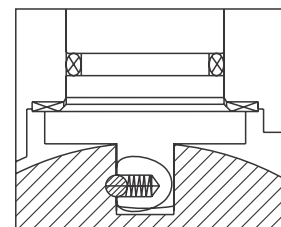

Product features to our customer benefit

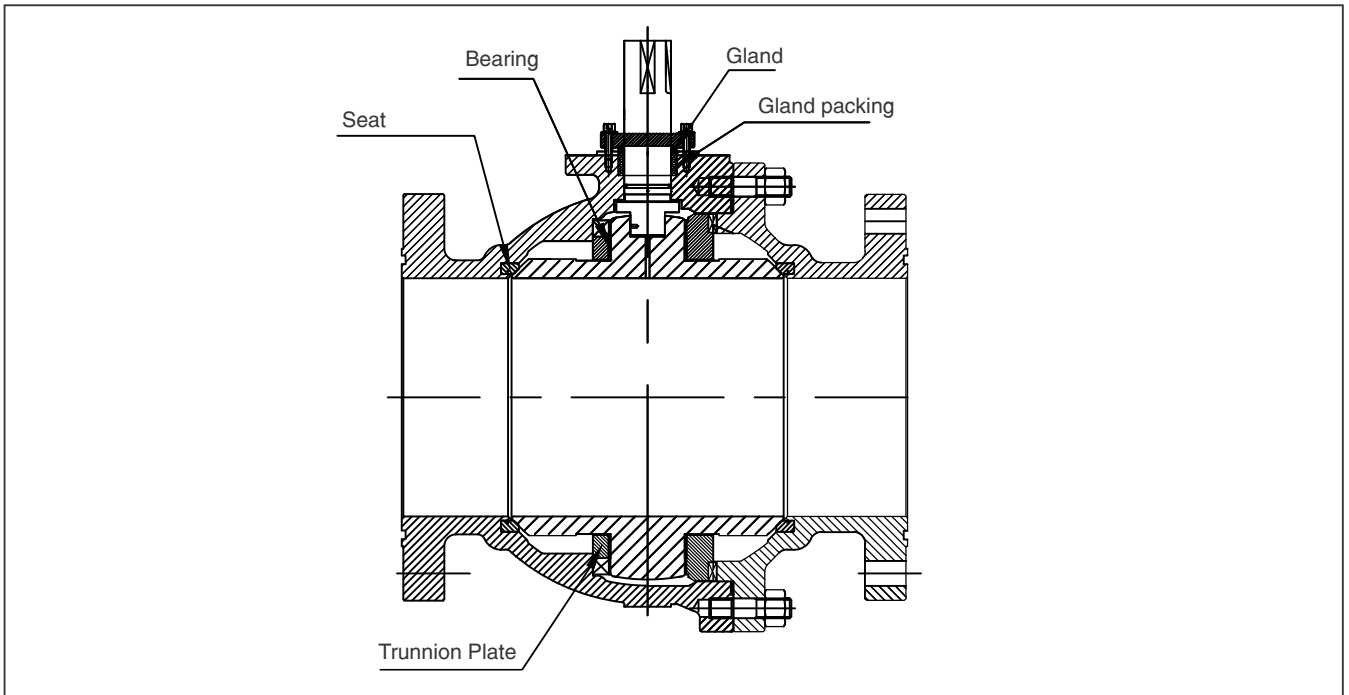

Trunnion Supported Ball

Internally mounted compact trunnion holder provides positive bearing support to ball. This also eliminates external leak paths present in external trunnion arrangement

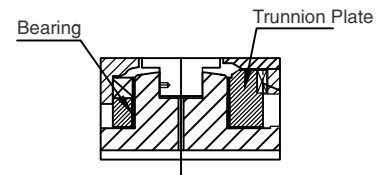

Floating Seat (Semi Trunnion)

Seat moves against ball because of special geometry. This reduce seat loading force on the ball and results in reliable leak tightness and lower torque

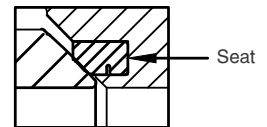

Spring Loaded Floating Seat

Seat moves against ball with the aid of spring. This provides double block & bleed feature. The operating torque and wear on the seats is relatively low, enhancing seat life.

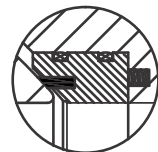

Emergency Sealant Injection

Emergency Sealant injection for seat and stem can be provided if required

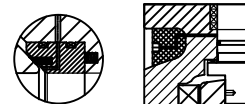

Drain Plug / Cavity Relief

Drain plug can be provided if required. Body Cavity Relief option is available

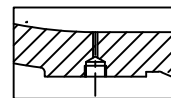

Leak-proof Stem Design

An 'O' ring elastomer seal and gland packing with preset compression forms a two stage sealing system for the stem. Disc spring provide live loading to ensure reliable stem sealing under varying temperature and pressure

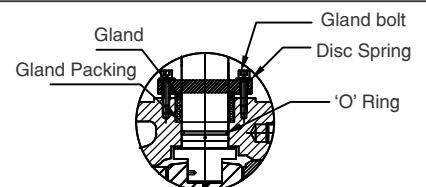

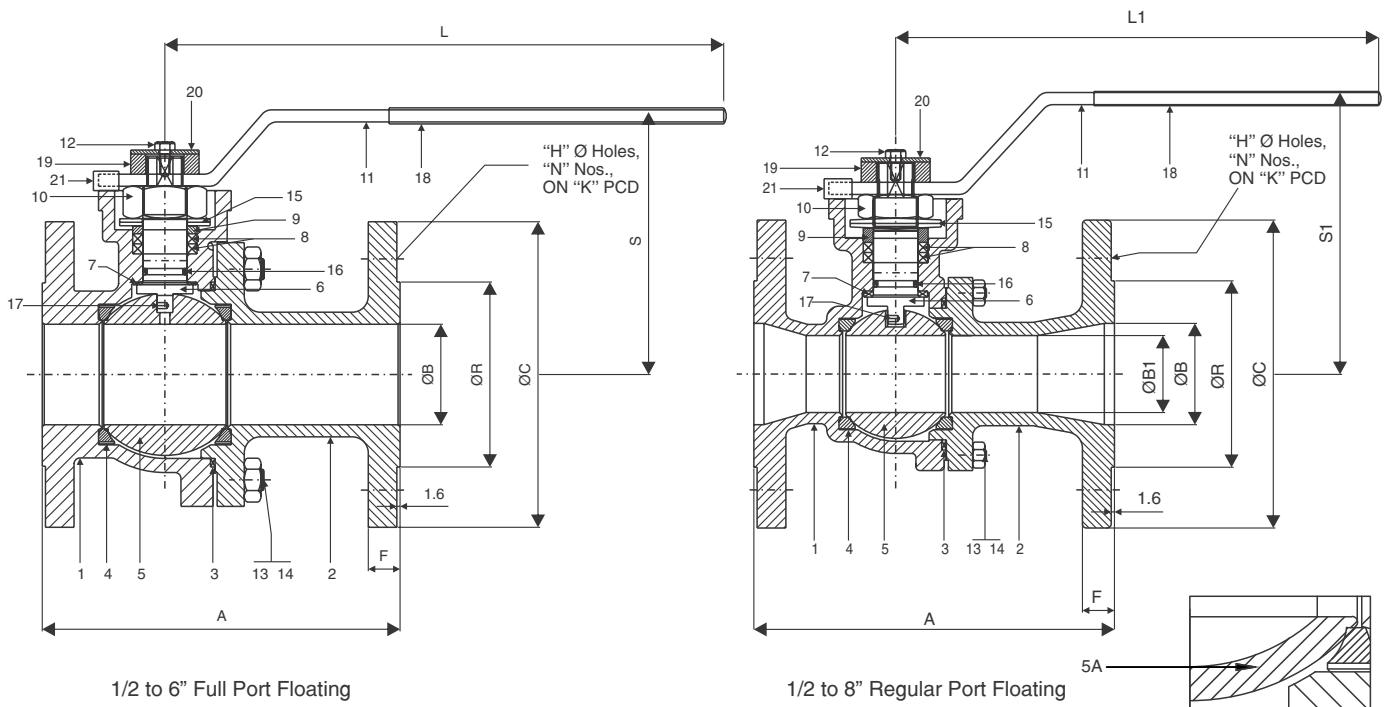

1/2 to 6" Full Port Floating

1/2 to 8" Regular Port Floating

 Hollow ball for class 150
 (1-1/2" to 6 FP, 2" -8"RP)

Dimensions in mm

Class 150									FP	RP	FP	RP	FP & RP	RP
Size	A		C	R	F	ØK	N	ØH	S	S1	L	L1	B	B1
	RP	FP												
DN 15	108	108	89	35	11.2	60.5	4	16	100	100	166	166	14	14
DN 20	117	117	98.5	43	11.2	70	4	16	101	100	166	166	20	20
DN 25	127	127	108	51	11.2	79.5	4	16	112	101	194	166	25	20
DN 40	165	165	127	73	14.3	98.5	4	16	127	112	278	278	38	32
DN 50	178	178	152	92	15.8	120.65	4	19	135	127	278	278	50	38
DN 65	190	190	178	105	17.6	139.7	4	19	160	135	318	278	63	50
DN 80	203	203	191	127	19.1	152.4	4	19	180	160	318	318	75	63
DN 100	229	229	230	157	24.0	190.5	8	19	205	180	318	318	100	75
DN 125	254	254	254	186	24.0	216.0	8	22.2	275	205	629	318	125	100
DN 150	267	394	279.5	216	25.5	241.3	8	22.2	290	205	750	318	150	100
DN 200	292	-	345	270	27.0	298.5	8	22.2	-	290	-	750	-	150
Class 300									FP	RP	FP	RP	FP & RP	RP
Size	A		C	R	F	ØK	N	ØH	S	S1	L	L1	B	B1
	RP	FP												
DN 15	140	140	95	35	14.3	66.7	4	16	100	100	166	166	14	14
DN 20	152	152	115	43	16.3	82.6	4	19	101	127	166	278	20	20
DN 25	165	165	125	51	17.9	89.0	4	19	112	127	194	278	25	20
DN 40	190	190	155	73	21.1	114.3	4	22.2	127	278	278	278	38	32
DN 50	216	216	165	92	22.4	127.0	8	19	135	127	278	278	50	38
DN 65	241	241	190.5	105	25.4	149.2	8	22.2	160	135	318	278	63	50
DN 80	283	283	210	127	28.5	168.1	8	22.2	180	160	318	318	75	63
DN 100	305	305	254	157	31.8	200.1	8	22.2	205	180	318	318	100	75
DN 125	381	381	279.5	186	35.0	235.0	8	22.2	275	205	629	318	125	100
DN 150	403	403	320	216	36.5	269.9	12	22.2	290	205	750	318	150	100
DN 200	502	-	381	270	41.2	330.2	12	25.4	-	290	-	750	-	150

FP - Full Port
RP - Regular Port

Materials - Floating ball

Part No.	Description	Material		
		ASTM A	ASTM A	ASTM A
1	Body	ASTM A 216 WCB	ASTM A 351 CF8	ASTM A 351 CF8M
2	Body Connector			
3	Body Seal	SWG	SWG	SWG
4	Ball Seat	PTFE	PTFE	PTFE
5	♦ Ball	CF8M/CF8	CF8	CF8M
6	Stem	SS316/SS304	SS304	SS316
7	Stem Seal	CFT	CFT	CFT
8	Gland Packing	Graphoil	Graphoil	Graphoil
9	Gland	SS316/SS304	SS304	SS316
10	Gland Nut	A 194-2H	A 194-8	A194-8M
11	Lever	MS Powder Coated	MS Powder Coated	MS Powder Coated
12	Lever Bolt	A 194-2H	A 194-2H	A194-2H
13	Body Stud	A 193-B7	A 193-B8	A193-B8M
14	Body Nut	A 194-2H	A 194-8	A194-8M
15	Disc Spring	Spring Steel	Spring Steel	Spring Steel
16	⊙ 'O' Ring	Viton	Viton	Viton
17	Antistatic Device	SS316	SS316	SS316
18	Lever Sleeve	PVC	PVC	PVC
19	Lever Spacer	Carbon Steel	Carbon Steel	Carbon Steel
20	Lever Washer	Carbon Steel	Carbon Steel	Carbon Steel
21	Stopper Pin	Carbon Steel	Carbon Steel	Carbon Steel

- ♦ Hollow ball for 150# (5A) **40mm to 150mm FP** and **50mm to 200mm RP**
- ⊙ 'O' ring provided for value size $\geq 50\text{mm}$ (FP) & $\geq 65\text{mm}$ RP

Test Specifications for WCB

Test	Medium	Class - 150		Class - 300	
		kg/cm ²	psi	kg/cm ²	psi
Shell	Water	32	456	80	1138
Seat	Water	23*	328*	58*	825*
Seat	Air	6	85	6	85

* Seat test pressure shall be as per the value indicated in the table above or 1.1 times the rated seat pressure given in the Pressure/Temp. Graph, whichever is less.

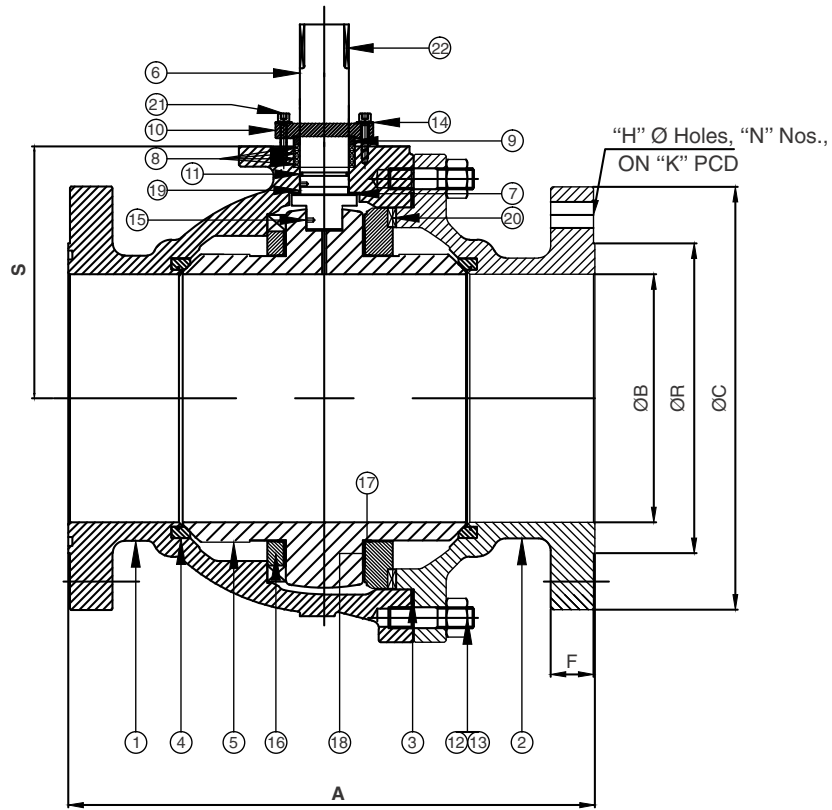

**8" to 12" Full Port
Semi Trunnion**

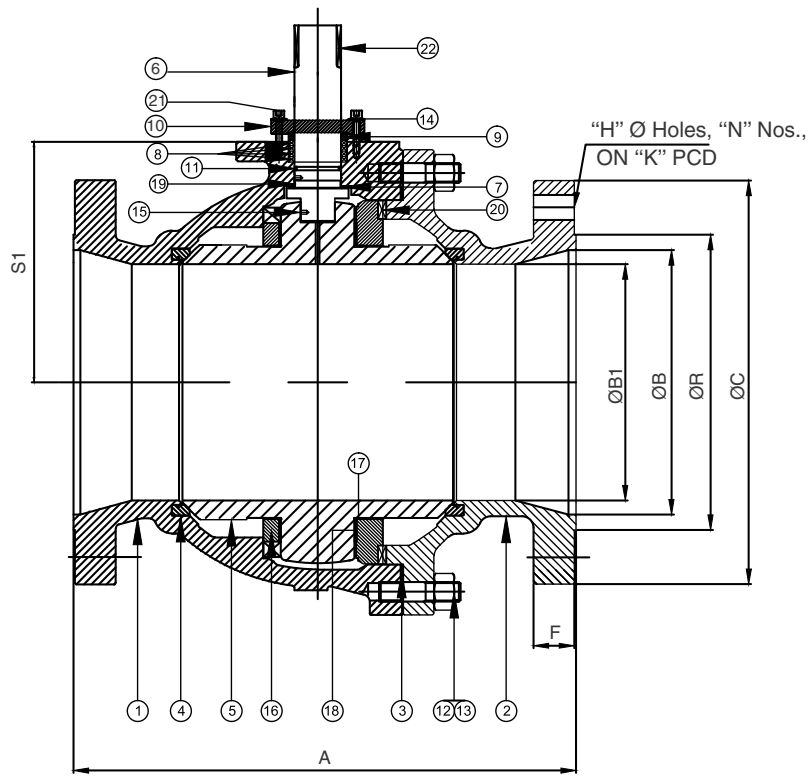

**10" to 14" Regular Port
Semi Trunnion**

Materials - Semi Trunnion

Part No.	Description	Material		
1	Body	ASTM A	ASTM A	ASTM A
2	Body Connector	216 WCB	351 CF8	351 CF8M
3	Body Seal	SWG	SWG	SWG
4	Seat	PTFE	PTFE	PTFE
5	Ball	CF8M/CF8	CF8	CF8M
6	Stem	SS316/SS304	SS304	SS316
7	Stem Seal	CFT	CFT	CFT
8	Gland Packing	Graphoil	Graphoil	Graphoil
9	Gland	SS316/SS304	SS304	SS316
10	Gland Adapter	Carbon Steel	SS304	SS316
11	'O' Ring	Viton	Viton	Viton
12	Body Stud	A 193-B7	A 193-B8	A193-B8M
13	Body Nut	A 194-2H	A 194-8	A194-8M
14	Disc Spring	Spring Steel	Spring Steel	Spring Steel
15	Antistatic Device	SS316	SS304	SS316
16	Trunnion Plate	CF8M/CF8	CF8	CF8M
17	Thrust Bearing	PTFE	PTFE	PTFE
18	Trunnion Bearing	PTFE	PTFE	PTFE
19	Stem Bearing	PTFE	PTFE	PTFE
20	Trunnion Key	SS316	SS304	SS316
21	Allen Bolt	A 194-2H	A 194-2H	A 194-2H
22	Stem Key	SS316	SS304	SS316

Test Specifications for WCB

Test	Medium	Class - 150		Class - 300	
		kg/cm ²	psi	kg/cm ²	psi
Shell	Water	32	456	80	1138
Seat	Water	23*	328*	58*	825*
Seat	Air	6	85	6	85

* Seat test pressure shall be as per the value indicated in the table above or 1.1 times the rated seat pressure given in the Pressure/Temp. Graph, whichever is less.

Dimensions in mm

Class 150									FP	RP	FP	RP	FP & RP	RP
Size	A		C	R	F	Ø K	N	Ø H	S	S1	L	L1	B	B1
	RP	FP												
DN 200	-	457	345	270	27.0	298.5	8	22.2	246	-	Gear box	-	201	-
DN 250	533	533	405	324	28.6	362	12	22.4	260	246	Gear box	Gear box	252	201
DN 300	610	610	485	381	30.2	431.8	12	25.4	315	260	Gear box	Gear box	305	252
DN 350	686	-	535	413	33.4	476.3	12	28.5	-	315	-	Gear box	-	305
Class 300									FP	RP	FP	RP	FP & RP	RP
Size	RP	A	C	R	F	Ø K	N	Ø H	S	S1	L	L1	B	B1
	FP													
DN 200	502	502	381	270	39.7	330.2	12	25.4	246	290	Gear box	750	201	150
DN 250	457	568	445	324	46.1	387.4	16	28.5	260	246	Gear box	Gear box	252	201
DN 300	502	648	520	381	49.3	450.8	16	31.8	315	260	Gear box	Gear box	305	252

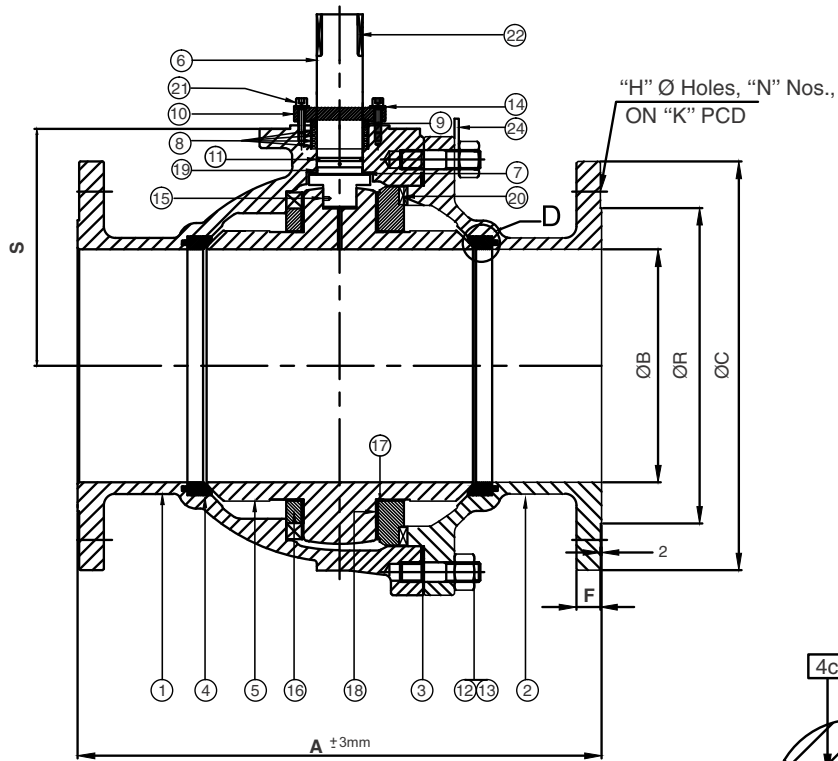

14" to 16" Full Port Trunnion

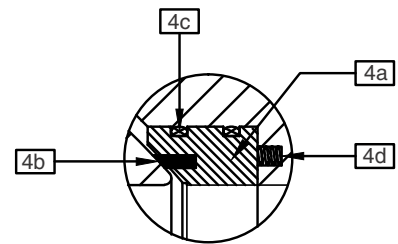

Detail - D

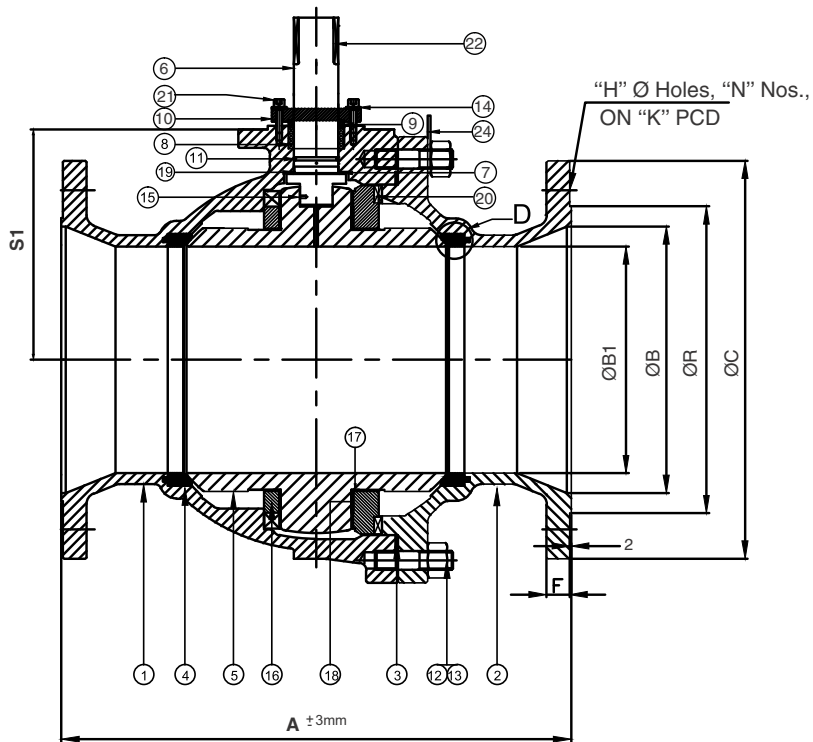

16" Regular Port Trunnion

Materials - Trunnion Mounted

Part No.	Description	Material		
1	Body	ASTM A	ASTM A	ASTM A
2	Body Connector	216 WCB	351 CF8	351 CF8M
3	Body Seal	SWG	SWG	SWG
4	Seat Assembly	-	-	-
4a	Seat Holder	SS316/SS304	SS304	SS316
4b	Seat	PTFE	PTFE	PTFE
4c	Seat 'O' Ring	Viton	Viton	Viton
4d	Spring	SS316/SS304	SS316	SS316
5	Ball	CF8M/CF8	CF8	CF8M
6	Stem	SS316/SS304	SS304	SS316
7	Stem Seal	CFT	CFT	CFT
8	Gland Packing	Graphoil	Graphoil	Graphoil
9	Gland	SS316/SS304	SS304	SS316
10	Gland Adapter	Carbon Steel	SS304	SS316
11	'O' Ring	Viton	Viton	Viton
12	Body Stud	A 193-B7	A 193-B8	A 193-B8M
13	Body Nut	A 194-2H	A 194-8	A194-8M
14	Disc Spring	Spring Steel	Spring Steel	Spring Steel
15	Antistatic Device	SS316	SS304	SS316
16	Trunnion Plate	CF8M/CF8	CF8	CF8M
17	Thrust Bearing	PTFE	PTFE	PTFE
18	Trunnion Bearing	PTFE	PTFE	PTFE
19	Stem Bearing	PTFE	PTFE	PTFE
20	Trunnion Key	SS316	SS304	SS316
21	Allen Bolt	A 194-2H	A 194-2H	A 194-2H
22	Stem Key	SS316	SS304	Ss316

Test Specifications for WCB

Test	Medium	Class - 150		Class - 300	
		kg/cm ²	psi	kg/cm ²	psi
Shell	Water	32	456	80	1138
Seat	Water	23*	328*	58*	825*
Seat	Air	6	85	6	85

* Seat test pressure shall be as per the value indicated in the table above or 1.1 times the rated seat pressure given in the Pressure/Temp. Graph, whichever is less.

Dimensions in mm

		Class 150							FP	RP	FP	RP	FP & RP	RP
Size	A		C	R	F	ØK	N	ØH	S	S1	L	L1	B	B1
	RP	FP												
DN 350	686	686	535	413	33.4	476.3	12	28.5	335	315	Gear box	Gear box	334	305
DN 400	762	762	595	470	35.0	539.8	16	28.5	415	335	Gear box	Gear box	385	334
		Class 300							FP	RP	FP	RP	FP & RP	RP
Size	A		C	R	F	ØK	N	ØH	S	S1	L	L1	B	B1
	RP	FP												
DN 350	762	762	585	412.8	52.4	514.4	20	31.8	335	315	Gear box	Gear box	334	305
DN 400	838	838	650	469.9	55.6	571.5	20	35	415	335	Gear box	Gear box	385	334

Pressure Temperature Graphs

Pressure Temperature Rating : PTFE Seat

(1) For 15 to 100 FP / 10 to 125 RP
 (2) For 125 to 150 FP / 150 to 200 RP

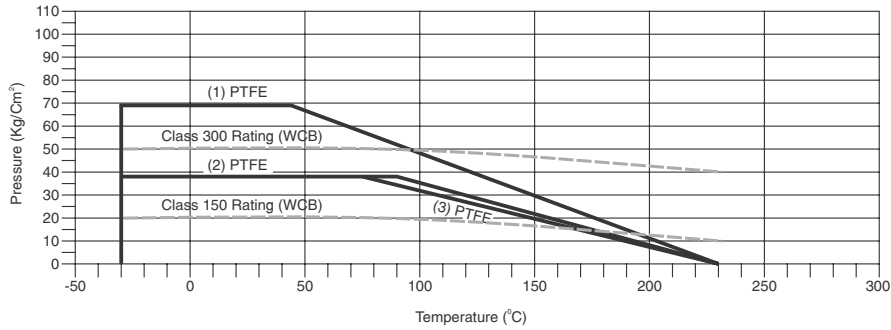

Pressure Temperature Rating : RPTFE Seat

(1) For 15 to 100 FP / 15 to 125 RP
 (2) For 125 to 200 FP / 150 to 200 RP

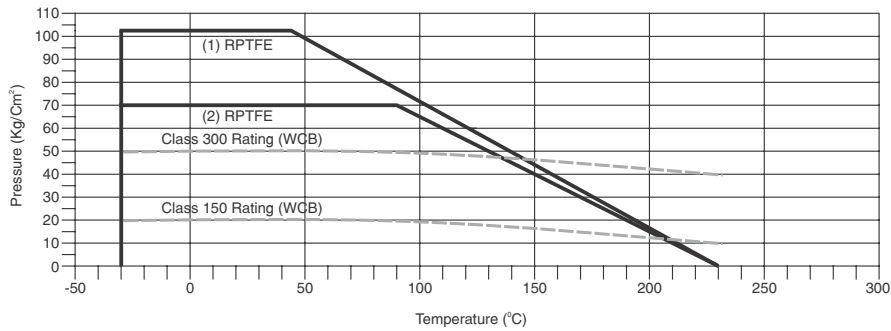

Pressure Temperature Rating : PEEK Seat

Note :- For sizes > 50mm, FP, contact KSB

(1) For 15 to 25 FP / 15 to 40 RP
 (2) For 40 to 50 FP / 50 to 65 RP

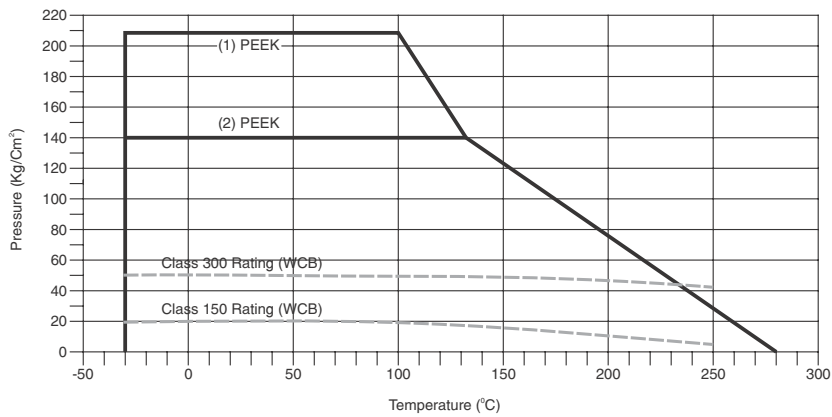

Pressure Temperature Rating : Nylon / Delrin Seat

Note :- For sizes > 50mm, FP, contact KSB

(1) For 15 to 25 FP / 15 to 40 RP
 (2) For 40 to 50 FP / 50 to 65 RP

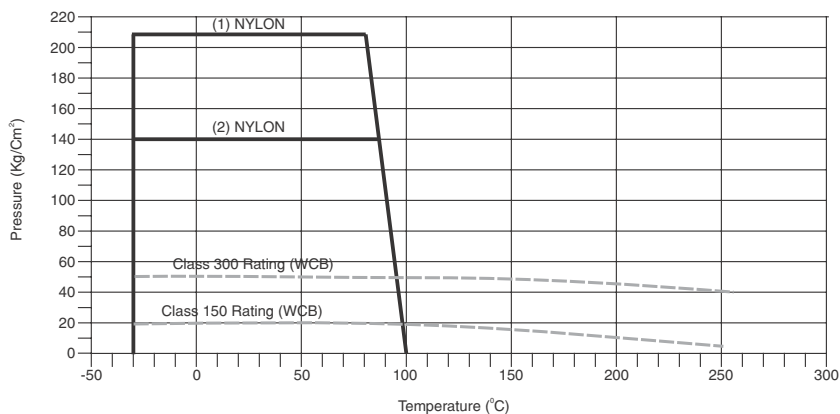

Pressure Temperature Graphs (Semi Trunnion)

Pressure Temperature Rating: PTFE Seat

(1) 200 to 300 FP/250 to 350 RP

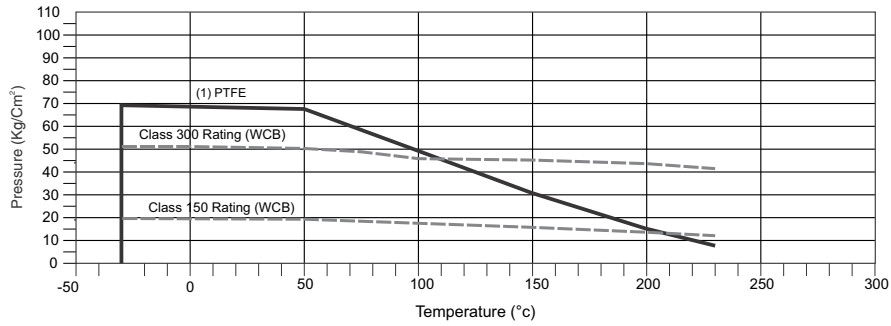

Pressure Temperature Rating: PTFE Seat

(1) 200 to 300 FP/250 to 350 RP

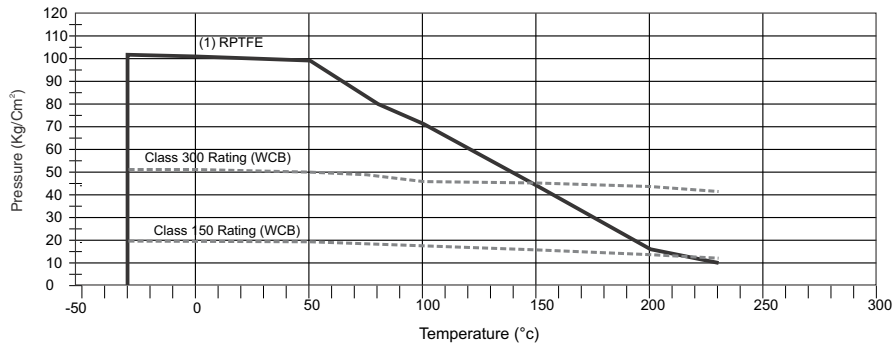



KSB Pumps Limited

151, Mettupalayam Road, NSN Palayam Post, Coimbatore 641 031. India.
Tel.: +91 422 2468222 Fax : +91 422 2468232 www.ksbindia.co.in

Technical matter subject to change without prior notice.