

A versatile shape-shifter

The cleverly-angled Bulk Pulverizers efficiently separate rebar from concrete in the secondary reduction stage.

Optional 360° endless hydraulic rotation allows optimal positioning and precise handling.

Faster working cycles thanks to the integrated speed valve.

Full hydraulic cylinder protection thanks to the piston rod guard.

Tooth plate is replaceable for easy maintenance.

Cutting blades are both replaceable and reversible.





The Bulk Pulverizers' smart design also makes them ideal for primary demolition of ceilings and walls.

BP range		BP 2050	BP 3050
Static version			
Carrier weight class ¹⁾	t	18–27	25–40
Service weight ²⁾	kg	2,090	3,100
Product weight	kg	1,890	2,750
A	mm	2,240	2,590
B	mm	875	1,020
C	mm	610	650
D	mm	190	190
X	mm	430	590
Y	mm	550	650
Rotating version			
Carrier weight class ¹⁾	t	22–27	30–40
Service weight ²⁾	kg	2,560	3,790
Product weight	kg	2,360	3,440
A	mm	2,630	2,990
B	mm	875	1,020
C	mm	610	650
D	mm	190	190
X	mm	430	590
Y	mm	550	650
Static and rotating version			
F1	t	290	365
F2	t	90	115
Cycle time (opening/closing)	sec	2,9/2,5	2,7/2,7
Oil flow rate (opening & closing)	L/min	150–250	150–250
Max. operating pressure (opening & closing)	bar	350	350
Oil flow rate (rotation)	L/min	35–50	35–50
Max. operating pressure (rotation)	bar	170	170

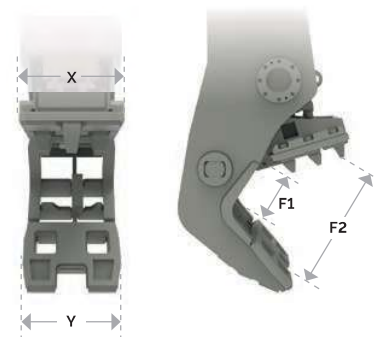
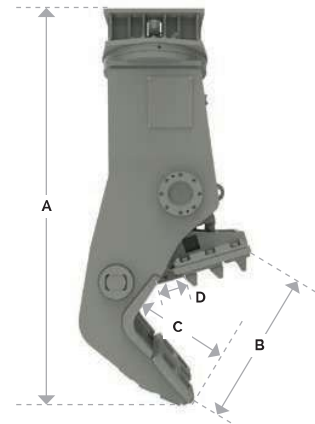

¹⁾ Weights apply to standard carriers only. Any variances must be agreed with Epiroc and/or the carrier manufacturer prior to attachment.

²⁾ Attachment with average-sized adapter plate.