



# ***Nordstrom® Valves*** ***Sealants and Sealant Equipment***



***Experience In Motion***



## To Access Literature Online

Every item in this catalog has a brochure containing a great deal of technical product detail. It's easy to find... it's free... and you do not need a password.

### Do This:

- 1 Go to [www.flowserve.com](http://www.flowserve.com)

- 2 Click in the box that says "Literature"

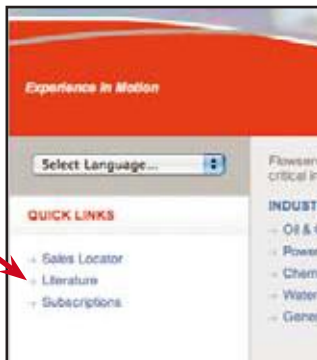

- 3 Enter keyword or literature number

- 4 Click on "Search"

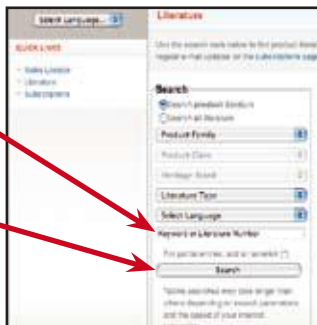

The most recent version of each product bulletin will be available on this site.

- Once you have the PDF, you can:
- read it
  - print it
  - download it
  - even e-mail it

## Table of Contents

Section	Page
What is Valve Sealant .....	3
Why Use Valve Sealants .....	3
Why Use Nordstrom Valves Sealants .....	4
Characteristics of Nordstrom Sealant .....	5
Nordstrom Sealant Selection Chart.....	6
Why Use Nordstrom Valves Injection Equipment ....	8
Injection Equipment .....	10
How To Order .....	11
Temperature Gradients .....	11

## Additional information available.

Operating instructions for the 400D Hydraulic Handgun can be found in document NVENIM2002, and operating instructions for the the Hypergun-Plus 5G can be found in documents NVENIM2003 and NVENIM2004. Just follow the instruction on the left "To Access Literature Online" It is fast and simple.

Also, for an overview of all Nordstrom Valves see the catalog NVENBR0001. Just follow the instruction on the left "To Access Literature Online"

## Ordering Preprinted Literature

Customers, please contact your Flowserve sales representative to get hard copy of a brochure. Flowserve representatives and distributors can go to [www.flowserve.com](http://www.flowserve.com) and click on the "View Literature" link then click on "Log-in to order hard copy literature" and follow the prompts.

To order hard copies, you will need to get a password, which may take up to a day or two.

## What is Valve Sealant?

- Forms a flexible renewable seal around the valve port.
- An integral part of every lubricated plug valve.
- Resists chemical attack and dissolving characteristics of line medium.
- Combines base oils, thickeners and additives.



## Why Use Valve Sealants?

**Drop-Tight Seal** - To secure an absolutely tight seal, the film of the sealant works to form a seal between the sealing surfaces of the valve. The seal is formed by sealant transmitted through a system of passageways around the valve port. With proper selection of sealant for your particular service, the seal can be retained over a wide range of temperatures and pressures.

**Lubrication** - Prevents metal-to-metal contact of the valve sealing services by filming over bearing irregularities. No matter how finely ground a metal surface may be, the metal is a series of peaks and valleys. As one metal slides against another, friction is set up and adhesion, shearing, or plowing may result. A protective film of sealant over the bearing area prevents metal-to-metal rubbing.

**Renewable Seat** - There is no need to disassemble a lubricated valve or remove it from service to replace mildly damaged seats. Sealant, as a structural part of lubricated valves, provides a flexible and renewable seat, eliminating the necessity of force fit contact to effect a seal. For this purpose, the sealant not only must have proper plasticity, but also resistance to line fluids such as solvents and chemicals. Sealant forms a seal between the sealing surfaces of the valve even under pressure.

**Plug Jacking** - The fundamental operating principle of the traditional lubricated plug valve design lies in the application of Pascal's Law. The law states that a unit pressure applied to the liquid contained in a sealed vessel is transmitted to every part of the liquid with undiminished force, thus multiplying the force many times, depending on the area of the interior of the vessel. The sealant, under pressure developed by sealant injection, supplies the hydraulic means for lifting the plug from its tapered seat when and if that force is needed to free the plug.

**Corrosion resistance** - Helps prevent corrosion of valve internals.

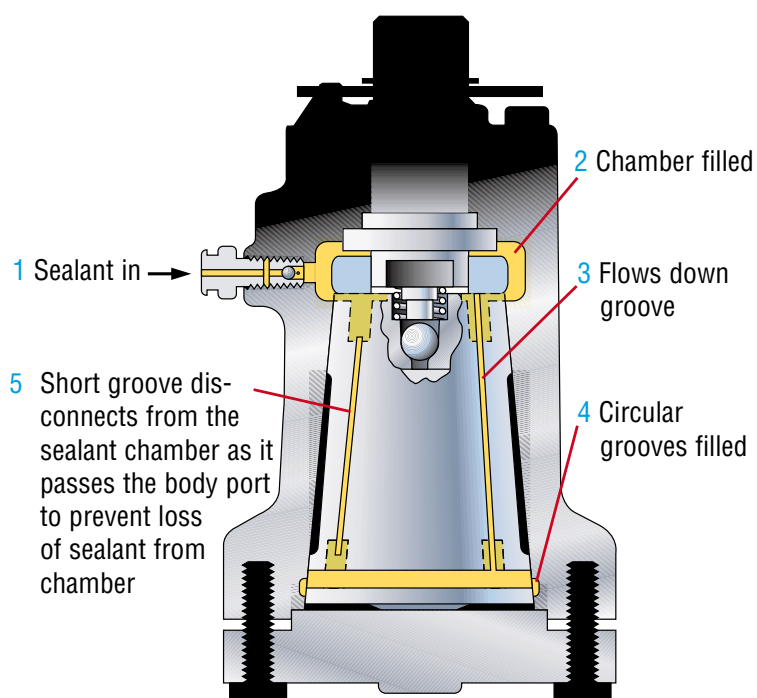

When the valve lifts from the seat, sealant spreads along the plug/body contact surfaces. This sealant spreads when the plug operates.

## Why Use Nordstrom Valves Sealants?

- Manufactured by the world's largest manufacturer of plug valves.
- Time-tested and proven by actual use in millions of valves.
- Nordstrom Valves Sealants have been tested to ensure maximum valve performance:
  - Valve operating torque
  - Solvent resistance
  - Water resistance
  - Shear force reaction
  - High and low temperature resistance
  - Degradation test
  - Sealability
- Laboratory tested to be environmentally safe and non-hazardous.
- Controlled manufacturing processes.
- Each batch of product traceable for a minimum period of five years.
- A wide variety of advanced valve sealant formulations available for different services.
- In-house technical expertise to ensure sealant quality and provide technical assistance when needed.



## Characteristics of Nordstrom Sealants

Sealant Number	Grades Available	Temperature Range °F (°C)		Color	Principle Services	Unsuitable for	Composition		
		From	To				Base Oil	Thickener	Additive
167	Stick	50 (10)	650 (343)	Tan	Air and gas dryer service, high temperature water, hot oil, steam and hot/oil steam combinations on burner front applications. Limit oxidizing services for 500°F.	Liquid light hydrocarbons, aromatic solvents, nitrating acids	Hydrocarbon	Silica, Inorganic Thickeners	Antioxidants
	Bulk	20 (-6.7)	650 (343)						
	SS Bulk	20 (-6.7)	650 (343)						
	Gun Pack	20 (-6.7)	650 (343)						
234	Tube	-40 (-40)	400 (204)	White	A silicone sealant for hot air, hot water, steam, high vacuum, acetic acid, acetic anhydride, ethyl alcohol below 250°F, natural gas compressor discharge, food and pharmaceutical applications as determined by the user. NSF 61 approved for use in potable water systems and U.S.D.A. H-1 approved for food applications	Gasoline and light liquid hydrocarbons, strong mineral acids, aromatic and chlorinated solvents.	Silicone	Silica	None
	Gun Pack	-40 (-40)	400 (204)						
	Bulk	-40 (-40)	400 (204)						
386	Stick	-20 (-29)	250 (121)	Cream	Dry or wet gas service, water works and sewage services as determined suitable by the user.	Services with organic solvents	Hydrocarbon	Metallic Soap Thickeners	None
	Bulk	-40 (-40)	250 (121)						
421	Stick	10 (-12)	350 (177)	Brown	Acids, alkalies, alcohols, amines, asphalt, aqueous solutions, fats, glycerine, glycols, soap, water and steam. Food and pharmaceutical applications as determined by the user. NSF 61 approved for use in potable water systems and U.S.D.A. H-1 approved for food applications	Liquid aliphatic or aromatic hydrocarbon solvents.	Hydrocarbon	Soap Thickener, Inorganic Non-soap Thickeners	None
	Bulk	0 (-173)	300 (149)						
	Gun Pack	0 (-173)	300 (149)						
555	Stick	-10 (23)	500 (260)	Brown	General purpose sealant for aliphatic hydrocarbon liquids and gases including gasolene, kerosene, fuel and lubricating oils, crude distillates, sweet or sour natural and manufactured gas with water or organic condensates, LPG systems, dilute acids and alkalies, glycols, textile plants, aqueous solutions, and water.	Aromatic solvents, strong chemicals, hot air.	Vegetable Oil	Inorganic Non-Soap Thickeners, Organic Thickeners	Antioxidants, Friction Modifier
	Bulk	-20 (-29)	500 (260)						
	SS Bulk	-20 (-29)	500 (260)						
	Gun Pack	-20 (-29)	500 (260)						
555 WG	Stick (J and K)	-20 (-29)	300 (149)	Brown	Same as 555 but use only for extreme and prolonged winter cold conditions.	Aromatic solvents, strong chemicals, hot air.	Vegetable Oil	Inorganic Non-Soap Thickeners, Organic Thickeners	Antioxidants, Friction Modifier
	Bulk	-40 (-40)	300 (149)						
	Gun Pack	-40 (-40)	300 (149)						
654	Stick	50 (10)	500 (260)	Brown	Solvent treating of lubricating oils, hot hydrocarbon vapors and gases, general hot oil service, asphalt.	Liquid light hydrocarbons, aromatic solvents, strong acids and chemicals.	Hydrocarbon	Soap, Organic Thickeners	None
	Bulk	0 (-18)	500 (260)						
	SS Bulk	0 (-18)	500 (260)						
	Gun Pack	0 (-18)	500 (260)						
755	Stick	30 (-1.1)	300 (149)	Pink	Benzene, butane, solvent naphthas, toluene, gasoline containing benzene or large amounts of aromatic hydrocarbons, carbon bisulfide, carbon tetrachloride, animal and vegetable oils.	Strong acids, nitrating acids, alcohols, water, aqueous solutions.	Polyglycols	Gel Thickeners	Corrosion Inhibitor
	Bulk	20 (-6.7)	300 (149)						
	Gun Pack	20 (-6.7)	300 (149)						
862	Stick	-85 (-65)	250 (121)	Tan	Natural gas transmission lines under variable extreme climatic temperatures and for air and inert gases at sub-zero temperatures.	Liquid hydrocarbon solvents or strong chemicals	Synthetic	Metallic Soap Thickeners	Antioxidants
	Bulk	-85 (-65)	251 (121)						
950	Stick	-20 (-29)	350 (177)	Cream	Excellent dual resistance to petroleum products and water. Particularly recommended for regular, premium and high octane gasoline, kerosene, aviation and jet fuels, fuel blending ingredients, such as alkylate and platformate, fuel and lubricating oils, mixtures of these products and water in all proportions. Usable to 400°F in non-oxidizing atmospheres.	Strong acids and alkalies.	Synthetic	Inorganic Non-Soap Thickeners,	Antioxidants, Copper Corrosion Inhibitor
	Bulk	-25 (-32)	350 (177)						
	SS Bulk	-10 (-32)	350 (177)						
	Gun Pack	-25 (-32)	350 (177)						
960	Bulk	-50 (-46)	300 (149)	Cream	Aliphatic liquids and gasses including gasolines, kerosene, fuel, and lubricating oils, hydrocarbon solvents and natural gas, neutral brines and salt solutions.	Strong acids and alkalies, aromatic and chlorinated solvents.	Synthetic	Inorganic Non-Soa Thickeners	Antioxidants, Friction Modifier
	Gun Pack	-50 (-46)	300 (149)						
1033	Stick (J and K)	-10 (23)	500 (260)	Green	General purpose sealant for liquid and gaseous aliphatic hydrocarbon service suitable for gasoline, kerosene, fuel oils, crude distillates, aviation and jet fuel, natural gas. Oxidation resistant formula minimizes problems associated with sealant hardening and solids buildup.	Aromatic solvents, strong acids and alkalies, steam.	Synthetic	Silica	Antioxidants, Corrosion Inhibitor
	Bulk	-20 (-29)	500 (260)						
	Gun Pack	-20 (-29)	500 (260)						
1045	Bulk	-30 (-34)	700 (371)	Black	Elevated temperature services involving hot hydrocarbon gases and vapors, water, steam, and aqueous solutions.	Liquid light hydrocarbons, aromatic solvents, and nitrating acids.	Synthetic	Organic Thickeners	Antioxidants
1200	Bulk	-33 (-36)	400 (204)	White	Highly resistant to extremely aggressive chemicals at low carbon dioxide concentrations.	Supercritical Fluids, Fluorinated Fluids	Synthetic	PTFE	None
	HT	-22 (-30)	550 (288)						
	LT	-94 (-70)	150 (66)						
1200 SS	HT	20 (-6.7)	650 (343)	Tan	Hot water, steam, hot oil, hot air, and coke oven gases.	Liquid light hydrocarbons, aromatic solvents, or nitrating acids.	Hydrocarbon	Silica, Organic Thickeners	Antioxidants

Nordstrom VXX valve cleaner is a combination cleaner and lubricant designed to soften and remoisturize dried sealant residues and deposits in clogged hard to operate valves. VXX valve cleaner is a microsilica-thickened vegetable oil product which is compatible with other valve lubricants / sealants and is not harmful to rubber parts. This product contains an organic molybdenum compound that will provide extra lubricity and help prevent galling and scoring. VXX valve cleaner is available in 1-quart bottles, 5-quart cans, or in Gun Pak form.

# Nordstrom Sealant Selection Chart

Due to varying service conditions, the recommendations in this chart are to be used as a guide in selecting the proper sealant. The specific properties of the sealants suggested should be checked with the more complete descriptions given on the preceding pages with particular regard to temperatures and services.

## Valve application / sealant number

### A

Acetaldehyde / 755  
 Acetate solvents / 755  
 Acetic anhydride / 421  
 Acetone / 421, 234  
 Acetylene gas / 421  
 Acids, general / 421  
 Acrylonitriles / 755  
 Air / 234, 950, 1033  
 Air Dryers / 167, 234 1033  
 Alcohols / 234, 421  
 Alkalies / 421  
 Alkyd resins / 755  
 Aluminum salt solutions / 421  
 Ammonia, gas or liquid / 421  
 Ammonium salt solutions / 421  
 Amyl chloride / 755  
 Aniline / 755  
 Aniline dyes  
     Hydrocarbon solvents / 755  
     Aqueous solvents / 421  
 Anodizing solutions / 421  
 Anthracene oil / 654, 167  
 Arsenic trichloride / 421  
 Asphalt / 654, 950, 1033  
 Asphalt emulsions / 421  
 Asphalt paints / 755

### B

Barium salt solutions / 421  
 Beet sugar liquors / 234  
 Benzaldehyde  
     Pure / 755  
 Benzene (benzol) / 755  
 Benzine / 950, 960, 1033  
 Bituminous paints / 755  
 Black liquor (paper industry) / 421  
 Blast furnace gas / 386, 654  
 Blood plasma / 234  
 Boiler water / 421, 167  
 Borax / 421, 960  
 Bromine / On application  
 Bulk stations / 950, 555  
 Bunker oils (fuel oils) / 950, 555, 1033  
 Butadiene / 950, 555, 1033  
 Butane / 950, 555, 1033

### C

Calcium hydroxide / 421  
 Calcium salt solutions / 421  
 Cane sugar liquors / 234  
 Carbon dioxide / 421, 960  
 Carbon disulfide / 755  
 Carbon monoxide / 234, 960  
 Carbonated beverages / 755  
 Castor oil / 755, 234  
 Caustic soda / 421  
 Cellosolve solvents / 755  
 Cellulose nitrate / 755  
 Chlorinated paraffin / 755  
 Chlorinated solvents / 755  
 Chlorine / On application  
 Chrome plating solutions / 421  
 Coal gas / 386, 421  
 Coal tar / 755, 555, 1033  
 Coat tar solvents / 755

Cocoon oil / 755, 234  
 Coke oven gas / 654  
 Compressor discharge  
     350°F & up / 167, 654  
 Compressor manifolds / 950, 167  
 Copper plating solution / 421  
 Copper sulfate / 421  
 Corn oil / 755, 234  
 Corn syrup / 234  
 Cottonseed oil / 755, 234  
 Creosote / 654, 555, 1033  
 Cresylic acid (cresol) / 421  
 Crude oil / 950, 555, 1033  
 Cumene / 755  
 Curb cocks / \*  
 Cutting oils, water emulsions / 555  
 Cyanide solutions / 421

### D

Dextrose / 234  
 Diesel fuel / 950, 555, 1033  
 Diethanolamine / 421  
 Diethylene glycol / 167, 421  
 Distillate, mineral oil / 950, 555, 1033  
 Dowtherm / 755, 167  
 Drilling mud / 555  
 Drinking water / 421  
 Dryer service / 167

### E

Electrolytic cell liquor / 234, 421  
 Epsom salts / 421  
 Ethane / 555, 1033  
 Ethanolamines / 421  
 Ether, ethyl / 755, 555, 1033  
 Ether, petroleum / 950, 555, 1033  
 Ethyl benzene / 755  
 Ethyl chloride / 755  
 Ethyl silicate / 555  
 Ethylene / 555  
 Ethylene glycol / 167, 421  
 Ethylene oxide / 755

### F

Fatty acids / 234  
 Ferric salts / 421  
 Ferrous salts / 421  
 Filling stations / 950, 555, 1033  
 Fish oil / 755, 234  
 Fluorine / On application  
 Food products / 234  
 Formaldehyde / 421  
 Freon / 755  
 Fruit juices / 234  
 Fuel oil / 950, 555  
 Furfural / 234, 167

### G

Gas dryers / 167, 234  
 Gas, manufactured / 555, 960, 1033  
 Gas, natural / \*  
 Gases, fuel / \*  
 Gas odorizers / 755  
 Gasoline / 950, 555, 1033  
 Glacial acetic acid / 234  
 Glucose / 234

## Valve application / sealant number

Glycerine (glycerol) / 234  
Grease / 755  
Green liquor / 421  
Green soap / 421

### H

Helium / 234  
Heptane / 950, 555, 1033  
Hexane / 950, 555, 1033  
Hot oil lines / 654, 167  
Hot water / 234, 167  
Hydrogen / 421  
Hydrogen peroxide / On application  
Hydrogen sulfide  
    Mixtures / 950, 555  
    Pure / 421

### I

Isobutane / 950, 555  
Isobutylene  
    Liquid / 950, 555  
    Vapor / \*  
Iso-octane / 950, 555, 1033

### J

Jet fuel / 950, 1033

### K

Kerosene / 950, 555, 1033  
Ketones (except acetone) / 755

### L

Lacquer solvents / 755  
Latex / 421  
Lead arsenate, slurry / 421  
Light naphthas / 950, 555, 1033  
Light oil, coal tar / 755  
Linseed oil / 234  
Liquefied petroleum gas (LPG) / 950, 555  
Lubricating oil / 654

### M

Magnesium salts / 234  
Magnesium hydroxide / 234  
Maleic acid (anhydride) / 234  
Manganous sulfate / 234  
Mash, distillery / 234  
Mercuric chloride / 234  
Mercury / 555  
Meter set-ups / \*  
Methane / \*  
Milk / 234  
Milk of lime / 421  
Mineral oil / 654, 555, 1033  
Mineral spirits / 950, 1033  
Molasses / 234  
Monochloroacetic acid / 234  
Monoethanolamine / 421  
Mud lines / 950, 555

### N

Naphtha / 950, 555, 1033  
Naphtha / 755, 167  
Naphthenic acid / 234  
Natural gas / \*  
Nickel plating solutions / 421

Nitrobenzene / 755  
Nitrogen / 386, 421  
Nitrogen solutions / 234  
Nitromethane / 755

### O

Octane / 950, 555, 1033  
Oil, petroleum / 950, 555, 1033  
Oil tar / 755, 167  
Oil-water mixtures / 950, 555  
Oleic acid / 234  
Oleum / 660  
Olive oil / 755, 234

### P

Paint thinner / 755  
Palm oil / 755, 234  
Palmitic acid / 234, 921  
Parafin / 755, 555, 1033  
Peanut oil / 234  
Pentane / 950, 555  
Petrolatum / 950, 555, 1033  
Petroleum ether / 950, 555, 1033  
Petroleum oil / 950, 555, 1033  
Phenol / 421  
Phosphorus oxychloride / On application  
Phosphorus trichloride / On application  
Phthalic acid (anhydride) / 167  
Pine resin / 755, 167  
Pitch / 755, 167  
Polyethylene / On application  
Polysibutylene / 755, 555  
Potassium salts / 234  
Producer gas / 167  
Propane / 950, 555  
Propylene  
    Liquid / 950, 555  
    Vapor / \*  
Propylene oxide / 755  
Pyridine / 755

### Q

Quench oil / 755, 555, 1033

### R

Residuum lines / 654  
Road tar / 755, 555, 1033  
Roofing pitch / 755, 555, 1033  
Rosin, solution / 421  
Rubber, latex emulsions / 421  
Rubber solvent / 755

### S

Salt solution / 421, 960  
Sea water / 960  
Separators, oilfield / 950, 555  
Sewage / 421  
Shellac / 421  
Silicone fluids / 755  
Soap solutions / 421  
Sodium (molten) / 234  
Sodium hydroxide / 421  
Sodium salt solutions / 421, 960  
Solder, molten / 234  
Soluble oil / 234, 654  
Soy bean oil / 755, 234

Stannic chloride / 421  
Starch solutions / 421  
Steam / 234, 167  
Stearic acid / 755, 234  
Stoddard solvent / 950, 555, 1033  
Strontium salt solutions / 421  
Styrene / 755  
Sugar solutions / 234  
Sulfate liquor / 421  
Sulfite liquor / 421  
Sulfonated oils / 755, 555, 1033  
Sulfur (molten) / 234, 167  
Sulfur chloride / 234  
Sulfur dioxide / 421  
Sulfur monochloride / 234  
Sulfur trioxide / 421  
Synthetic tannis / 421

### T

Tall oil / 234, 167  
Tallow / 234, 167  
Tannic acid / 421, 167  
Tanning liquors / 421, 167  
Tar / 755, 654, 1033  
Tartaric acid / 421, 167  
Tempering oil / 755, 555, 1033  
Tetraethyl lead / 755  
Titanium tetrachloride / On application  
Toluene / 755  
Triethanolamine / 421  
Tri-sodium phosphate / 421  
Turpentine / 755

### U

Ucon fluids / 234, 167

### V

Vacuum lines / 234  
Varnish / 234  
Vegetable oils / 234  
Vegetable tannis / 421  
Vinyl chloride / 755  
Vinylidene chloride / 755

### W

Water / 167, 421  
Water gas  
    Dry / 555  
    Wet / 950, 555  
Wax emulsions / 421  
Waxes / 755  
Whiskey / 234  
White liquor (paper industry) / 421  
White water (paper industry) / 421  
Wine / 234

### X

Xylene (xylol) / 755

### Z

Zinc salts / 421

\* Below 0°F 960, 1033  
Above 0°F 555, 1033

## Sealant Injection Equipment

### How is Sealant Injected into Valves?

- Manually ..... A, B, C, D, and G Sticks
- Hypregun-Plus 5Q..... five-quart can
- Hypregun-Plus 5G..... five-gallon pail
- 400-D Hydraulic Hand Gun ..... J-Stick or Gun Pak
- 400-A Hand Gun ..... J-Stick or K-Stick
- 400-B Bucket Pump ..... 30-pound bulk capacity

For more detailed information on sealant injection equipment, refer to specific product brochures.

### 400-D Hydraulic Hand Gun

The Flowserve Nordstrom 400-D High-Pressure Hand Gun is rated at 10,000-11,000 psi (690-759 bar) and includes many features for meeting the exact demands of replacing sealant in lubricated valves.

- Operates effectively in all positions.
- Air entrapment eliminated by adding fluid when recharging, automatically purging the system of air.
- The large fluid capacity permits long periods of operation between recharging.
- Solid floating piston without the use of a capscrew eliminates fluid leakage and eventual operation failure.
- Specially formulated hydraulic fluid in the pumping mechanism allows the gun to pump smoothly and with minimum effort.
- The powerful hydraulic floating piston principle forces sealant out of the gun with ease, regardless of the sealant viscosity.
- Equipped with a Giant Button Head Coupler for connection to the button head sealant fitting of the valve.
- “Built-in” safety features provide maximum safety both to the user and the gun itself. The internal relief valve protects the operator if pumping continues after the gun depleted of sealant.
- Dependable performance under all conditions.
- Includes 15,000 psi gauge.
- Perfect for tight quarters and for use on 6” and smaller valves.

In designing the 400-D Hand Gun, engineers concentrated on greatly simplifying maintenance and repair procedures. In most cases, the gun can be easily maintained and repaired by valve service personnel, without requiring factor service. Refer to NVENIM2002 for further Assembly Operation and Maintenance Instructions.





## Hypregun-Plus 5Q & 5G

The Flowserve Nordstrom Hypregun-Plus 5Q and the Flowserve Nordstrom Hypregun-Plus 5G were developed using the original Nordstrom Hypregun design and modifications as suggested by many Hypregun owners. This design continues to meet field and plant maintenance needs of valve users.

- Ideal for large scale valve servicing in refineries, compressor stations, gasoline plants, cycling plants, pipelines, and manifold installations. Versatile design for servicing small or large valves.
- Compact, highly efficient, air operated sealant injection devices with a 100:1 pressure ratio and double acting piston.
- Continued positive pressure applied to the side cylinders assures intimate contact between the follower plate and sealant makes it possible to pump sealant at much lower temperatures.
- The follower plate is engineered to promote flow of sealant to the foot valve at all workable air pressures but air pressure between 100 and 125 psi (6.9 to 8.6 bar) provide the most efficient operation. The air motor is rated to 125 psi (8.6 bar) and the Hypreguns should not be operated with pressures exceeding this rating.
- The air motor uses a maximum of 11.4 cubic feet of air per minute when operated at 125 psi (8.6 bar) with zero load. Reduced air pressure and increased load reduce air consumption although not linearly.
- Moisture traps (not supplied with the guns) can be used to prevent moisture from reaching the air motor which can condense and freeze causing the air motor to stall.
- Sealant cans have been materially strengthened with welded seams and are standard for all Nordstrom bulk sealants.
- The can shield supplied with each gun gives added strength to the can.
- The sealant cans and can shields have been developed specifically for use with Nordstrom Hypregun-Plus devices and it is not recommended using containers of sealants developed by other manufacturers.
- The Hypregun-Plus 5Q uses 5 quart (4.7 litre) sealant cans. The Hypregun-Plus 5G uses 5 gallon (18.9 litre) sealant cans. Both guns work well for all size valves.
- A 5 quart conversion kit is also available for the Hypregun 5G and provides the option of using a 5 quart can in the 5 gallon gun.
- Refer to NVENIM2003 for Hypregun 5Q and NVENIM2004 for Hypregun Plus 5G for further Assembly, Operation and Maintenance Instructions.



## Injection Equipment

### Giant Button-head Coupler

- Comes standard on all Nordstrom Valves sealant injection equipment.
- Allows easy connection to a valve's button-head sealant fitting.
- Automatically locks to the sealant fitting when the gun is pressurized.
- Coupler cannot be attached or removed from the fitting with the gun under pressure.
- Sealant will not pass through coupler unless connected to the valve sealant fitting.



### 400-B Bucket Pump

- Powerful, lightweight and portable.
- Hand-operated 15,000 psi sealant injection.
- Includes 15,000 psi gauge.
- 30-pound bulk capacity.
- Designed for heavy bulk lubricants.
- Easy to use.

### 400-A Hand Gun

- Polished hardened steel piston in high-pressure barrel.
- Powerful spring-loaded primer piston allows 30 or more strokes without repriming.
- Check valve and bleeder relief valve.
- Positive action makes the 400-A easy to handle and use.
- Includes shoulder strap.
- Uses convenient J-Stick and K-Stick sealants.
- Includes 15,000 psi gauge.



## How To Order

Inquiries and orders for Flowserve Nordstrom sealants and sealant injection equipment should always include complete descriptions so that the proper sealant is supplied. The following information is required at the time of order placement. If you are uncertain which sealant formula is required for your application, please contact the factory for further assistance.

### Stick Grade Sealant Ordering Information Requirements

- Quantity
- Container Type (Box)
- Formula Number
- Product Size
- Sticks Per Box

**Example:** qty. 3, Boxes, 1033, Size J, 6 sticks per box

### Stick Grade Sealant Sizes and Packaging

Flowserve Nordstrom stick-grade sealants are high-viscosity sealants for manual injection with a Combination Button-Head Fitting or for use with the 400-A or 400-D Hand Guns. The sealant is a consistency that maintains its extruded shape. The following chart lists available stick sizes and the method of injection.

Product Size	Sticks per Box	Boxes per Case*	Diameter		Length		Injection Method
			mm	in.	mm	in.	
A	24	n/a	6.4	0.25	22.4	0.88	Manually
B	24	150	9.7	0.38	35.1	1.38	Manually
C	24	120	14.0	0.55	50.8	2.00	Manually
D	24	50	16.8	0.66	62.0	2.44	Manually
G	24	24	21.8	0.86	85.9	3.38	Manually
J	6	10	37.3	1.47	222.3	8.75	400-D or 400-A Hand Gun
K	12	n/a	38.9	1.53	254.0	10.00	400-A Hand Gun

\* Stick grade sealants are sold by the box; however, for storage convenience, stick sealant boxes can be packaged and shipped in cases.

### Sealant Injection Equipment

Provide equipment description. Refer to pages 8, 9 & 10 for information on sealant injection equipment.

### Bulk Grade Sealant Ordering Information Requirements

- Required quantity
- Formula number
- Container size

**Example:** qty. 2, 1033, 5 quart can

### Bulk Grade Sealant Packaging

Flowserve Nordstrom bulk grade sealants are injected into valves using all models of Flowserve Nordstrom sealant injection equipment and are available in various packaging forms, depending upon the method chosen for valve injection. Super Soft bulk grade sealant (SS) is available in 950, 555, and 167. SS sealant has improved "pumpability" characteristics and must be ordered as "SS".

Container Size	Units per Container	Containers per Case	Injection Method
5.3 oz. Tube <sup>(1)</sup>	2 tubes per box	n/a	Manually
Cartridge <sup>(2)</sup>	4 cartridges per box	n/a	Standard Grease Gun <sup>(3)</sup>
Gun Pak	6 Gun Paks per box	10	400-D Hand Gun
5 Quart Can	5 Quarts	1, 2 or 4	Hypregun Plus 5Q
5 Gallon Pail	5 Gallons	1	Hypregun Plus 5Q
16 Gallon Drum	16 Gallons	n/a	Pump
55 Gallon Drum	55 Gallons	n/a	Pump

(1) Plastic tubes are standard packaging only for 234 sealant

(2) Cartridge dimensions are 2.07" (53.0 mm) by 9.25" (236.8 mm) (15 ounce).

(3) Not sold by Flowserve

### Valve Cleaner

VXX Valve Cleaner is packaged the same as bulk grade sealant.

Example: qty. 4, VXX Valve Cleaner, 5 quart Can.

**Flowserve Nordstrom Valves**

1511 Jefferson Street  
Sulphur Springs, Texas 75482  
USA

**United States:**

Telephone: 903-885-4691 or 4693  
FAX: 903-439-3411

**Latin America:**

Telephone: 903-439-3407  
Fax: 903-439-3411

**Other Countries:**

Telephone: 903-885-4692  
Fax: 903-439-3404

*To find your local Flowserve representative,  
visit [www.flowserve.com](http://www.flowserve.com) or call USA 1 800 225 6989*

# AUDCO ITALIANA

[www.audco.it](http://www.audco.it)

**FCD NVENBR1014-01 07/08 Printed in USA.**

Flowserve Corporation has established industry leadership in the design and manufacture of its products. When properly selected, this Flowserve product is designed to perform its intended function safely during its useful life. However, the purchaser or user of Flowserve products should be aware that Flowserve products might be used in numerous applications under a wide variety of industrial service conditions. Although Flowserve can (and often does) provide general guidelines, it cannot provide specific data and warnings for all possible applications. The purchaser/user must therefore assume the ultimate responsibility for the proper sizing and selection, installation, operation, and maintenance of Flowserve products. The purchaser/user should read and understand the Installation Operation Maintenance (IOM) instructions included with the product, and train its employees and contractors in the safe use of Flowserve products in connection with the specific application.

While the information and specifications contained in this literature are believed to be accurate, they are supplied for informative purposes only and should not be considered certified or as a guarantee of satisfactory results by reliance thereon. Nothing contained herein is to be construed as a warranty or guarantee, express or implied, regarding any matter with respect to this product. Because Flowserve is continually improving and upgrading its product design, the specifications, dimensions and information contained herein are subject to change without notice. Should any question arise concerning these provisions, the purchaser/user should contact Flowserve Corporation at any one of its worldwide operations or offices.

© 2003 Flowserve Corporation, Irving, Texas, USA. Flowserve is a registered trademark of Flowserve Corporation.