



Surface drill rigs

AirROC D35, T25 / D40, T35 / D45 / D50
Hole Diameter : 48 - 140 mm



United in performance. Inspired by innovation.

Performance unites us, innovation inspires us, and commitment drives us to keep moving forward. Count on Epiroc to deliver the solutions you need to succeed today and the technology to lead tomorrow. epiroc.com

Epiroc Mining India Limited
Bombay - Pune Road, Sveanagar Dapodi, Pune 411012,
Maharashtra - India.
Email: miningtechnique.india@epiroc.com



AirROC D35 (LM 100)

Hole range : 76 - 115 mm

Features and technical information

The AirROC D35 is the smallest and most popular of our crawler mounted, down the hole drilling rigs. This robust pneumatic rig is self propelled, easy to operate and simple to maintain. A single operator machine with outstanding flexibility, the AirROC D35 is an ideal choice for development work in confined areas or production drilling on developed benches.

This compact crawler has a main frame walking beam oscillator that ensures tracks adapt to uneven terrain. Tramming controls are located beside the left track. A 7.5 hp (5.5 kW) air powered hydraulic pump ensures efficient operational positioning. Powered by two independent 4.5 hp air motors for quick and smooth tramming the AirROC D35 is equipped with the heavy duty BRH rotary head for Down-the-Hole drilling.



Technical data

Carrier

Tramming speed, max	2.5 km/h	1.6 mph
Track oscillation	±10°	

Steel feed

Feed extension	750 mm	29.4"
Feed rate, max	0.3 m/s	59.0 ft/min
Feed force, max	21 kN	4 720 lbf
Tractive pull, max	15 kN	2 645 lbf
Total length	5 130 mm	202"
Travel length	3 565 mm	140.4"

Drill tube size	64, 76 mm	2.5", 3"
-----------------	-----------	----------

Transport dimensions

Transportation position

Height	2 325 mm	7'7 1/2"
Length	5 120 mm	16'9 1/2"
Width	1 940 mm	6'4 1/2"

Weight	2 690 kg	5 480 lb
--------	----------	----------

Drill coverage area

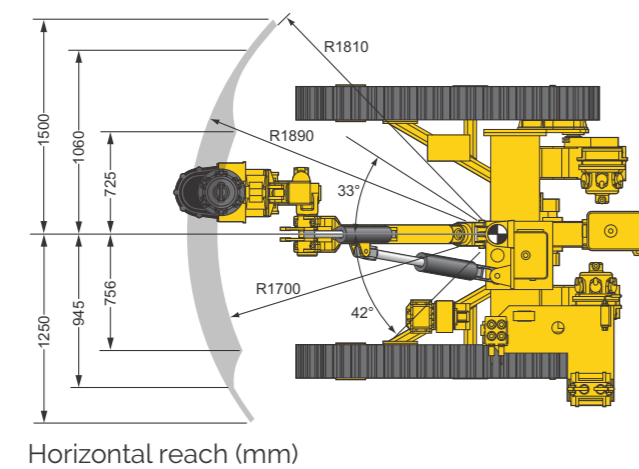

AirROC T35 / D45 / D50 (CM 341)

Hole range :

AirROC T35, 64 - 102 mm
AirROC D45, 105 - 127 mm
AirROC D50, 105 - 140 mm

Features and technical information

The AirROC T35/ D45/ D50 are high-powered, down the hole pneumatic drill rigs with exceptional mobility and performance. Robust traction, a low center of gravity and easy operator access to tramming and drill controls ensure reliable productivity in the toughest terrain. The AirROC T35/ D45/ D50 is ideally suited to development and production drilling in open pit mines and stone quarries.

The AirROC T35/ D45/ D50's twin tracks are powered by an 11.4hp air motor coupled to an enclosed gear drive with tramming and drilling controls easily accessed over the left hand track. A guide extension adjusts the guide foot ensuring optimal ground contact on slopes and rough terrain. A fine regulator helps the operator align the hole for optimal drilling operations. A piston type air feed motor drives the extra heavy roller chain providing 12kN(2698 lbf) of pull power.

Technical data

Carrier

Tramming speed, max	3.0 km/h	1.86 mph
Track oscillation	±10°	

Steel feed

AirROC T35, AirROC D45, AirROC D50		
Feed extension	1 219 mm	48"
Feed rate, max	0.25 m/s	49.2 ft/min
Feed force, max	21 kN	4 720 lbf
Tractive pull, max	14 kN	3 372 lbf
Total length	5 750 mm	226.3"
Travel length	4 250 mm	167.3"

Drill tube / Rod size

Drill rig	Rod / Pipe size	
AirROC T35	38, 45 mm	1.5", 1.75"
AirROCD45	76 mm	3"
AirROC D50	76, 89, 102 mm	3", 3.5", 4"

Transport dimensions

Transportation position		
Height	2 430 mm	8'
Length	5 750 mm	18'10 .5"
Width	2 480 mm	8'2"

Weight

AirROC T35 / D45 / D50	4 800 kg	10 582 lb
------------------------	----------	-----------



Drill coverage area

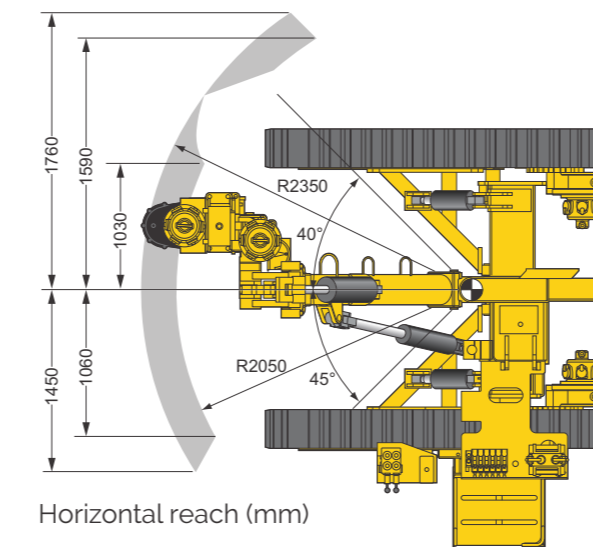

AirROC T25 / D40 (ROC 203)

Hole range :

AirROC T25, 48 - 76 mm
AirROC D40, 89 - 115 mm

Features and technical information

A highly adaptable drilling rig well known for its versatility and ease of use, the AirROC T25 / D40* is an ideal choice for construction, mining or quarry work where the approaches or terrain present operational challenges. With its reliable lightweight design and independent track oscillation system this robust pneumatic rig delivers proven reliability in the most challenging terrain.

The AirROC T25 / D40* is equipped with a feed re- pinning mechanism for toe-hole and horizontal drilling operations. An optional conversion kit offers down the hole or tophammer versatility. An independent track oscillation system powered by hydraulic motors and a planetary gear drive provide excellent traction on undulating terrain.

- AirROC T25* is equipped with BBC120F drifter for Tophammer Application (48mm-76mm hole dia)
- AirROC D40* is a Down the hole drill with BBR4 Rotation unit (89mm-115mm)

Technical data

Carrier

Tramming speed, max	2.5 km/h	1.6 mph
Track oscillation	±12°	

Steel feed

AirROC T25		
Feed extension	800 mm	31.5"
Feed rate, max	0.3 m/s	59 ft/min
Feed force, max	8 kN	2 645 lbf
Tractive pull, max	5 kN	2 204 lbf
Total length	5 450 mm	214.6"
Travel length	3 940 mm	155"

AirROC D40

Feed extension	800 mm	31.5"
Feed rate, max	0.3 m/s	59 ft/min
Feed force, max	8 kN	1 798 lbf
Tractive pull, max	5 kN	1 124 lbf
Total length	5 450 mm	214.6"
Travel length	4 009 mm	157.8"

Drill tube / Rod size

Drill rig	Pipe size	
AirROC T25	32, 38 mm	1.25", 1.75"
AirROC D40	76 mm	3"



Transport dimensions

Transportation position		
Height	1 780 mm	70"
Length	5 450 mm	215"
Width	1 880 mm	74"

Weight

AirROC T25	2 480 kg	5 467 lb
AirROC D40	2 515 kg	5 545 lb

Drill coverage area

