

AirROC D35SH

Epiroc surface DTH drill rigs
Hole range 102-115 mm



AirROC D35SH

“Compact little power-house” for DTH drilling

AirROC D35SH is a semi-hydraulic drill from Epiroc. This compact, highly reliable drill is a move towards graduating pneumatic drill users for a more efficient but simple hydraulic concept. This would give clearly visible benefits of lower fuel consumption and higher productivity. This is an ideal choice for DTH drilling as it fits in with ease for development and production drilling in applications like Aggregate Quarry, Civil Engineering, Construction and Selective Mining.

The AirROC D35SH with 5000 kgs weight is a down the hole hammer drill rig with entire function powered by hydraulics except the DTH hammer. This drill has onboard diesel engine which is a source of power for the hydraulic system. Main functions including tramming, set-up, boom movement, track oscillation, feed mechanism and rotation unit are hydraulically powered. AirROC D35SH is powered by the reliable onboard 50 HP Mahindra Diesel engine. The hydraulic system is well synchronized to meet the demand of this drill. It has a heavy duty feed mechanism which can generate tractive pull of 20kN along with powerful rotation unit which provides high rotation torque to tackle challenging rock formations.

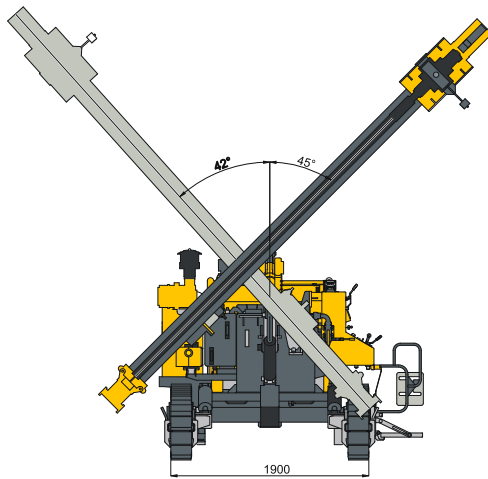

Feed swing angle (left and right)

AirROC D35SH is designed and tested for demanding work conditions. The rig's low center of gravity and high ground clearance provides smooth mobility over the most challenging terrain.

Thanks to on-board engine, utilization of optimum available working pressure and FAD from portable compressor, you will achieve lower fuel consumption as compared to pneumatic drills giving overall higher productivity. Recommended compressor capacity would be 450 to 500 cfm with 150-200psi

Technical snapshot

Engine Model	Mahindra diesel engine : 38KW/ 50 HP
Rod Dia Length	23/8", 76 mm x 3000 mm Starter Rod : 1800mm
Feed, Rotation, Tramming	Hydraulic
Tractive Pull	20 KN
Rotation Torque	1200NM
Tramming Speed	3.2 Kmph max
Ground Clearance	284mm
Track Oscillation	± 10
Weight	5000 kg
Options	Water mist system
Dimension	L : 5519 mm W : 2070 mm H : 2755 m

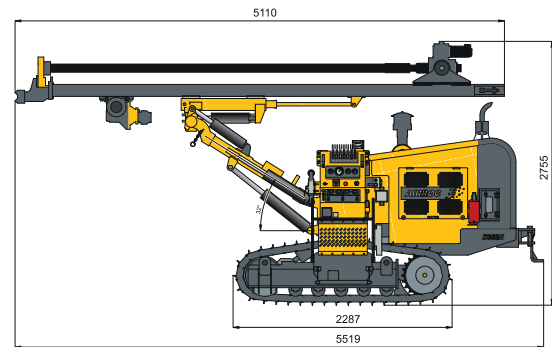

Transport dimension

**United in performance.
Inspired by innovation.**

Performance unites us, innovation inspires us, and commitment drives us to keep moving forward. Count on Epiroc to deliver the solutions you need to succeed today and the technology to lead tomorrow.
epiroc.com

Epiroc Mining India Limited
Bombay - Pune Road, Sveanagar, Dapodi,
Pune - 411 012, Maharashtra - India.
Email: miningtechnique.india@epiroc.com
Call us : 1800 120 1558

