

Amamix – Submersible mixer

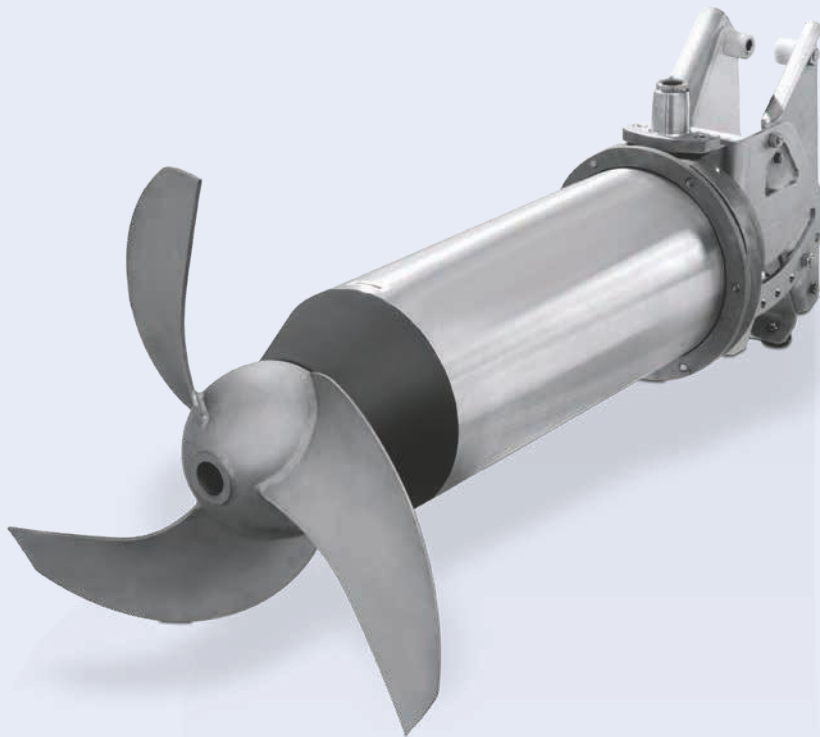

Applications:

- Mixing tanks
- Sludge storage tanks
- Balancing tanks
- Sewage tanks
- Stormwater stand-by tanks
- Digesters
- Thickeners
- Ice prevention
- Nitrification tanks
- Denitrification tanks
- Phosphate removal tanks
- Flocculation tanks
- For flow acceleration
- Pump sumps

More information:

www.ksb.com/products

Intelligent monitoring



Amacontrol III – Protection Module
for Water and Waste Water Products

Amamix – Submersible mixer

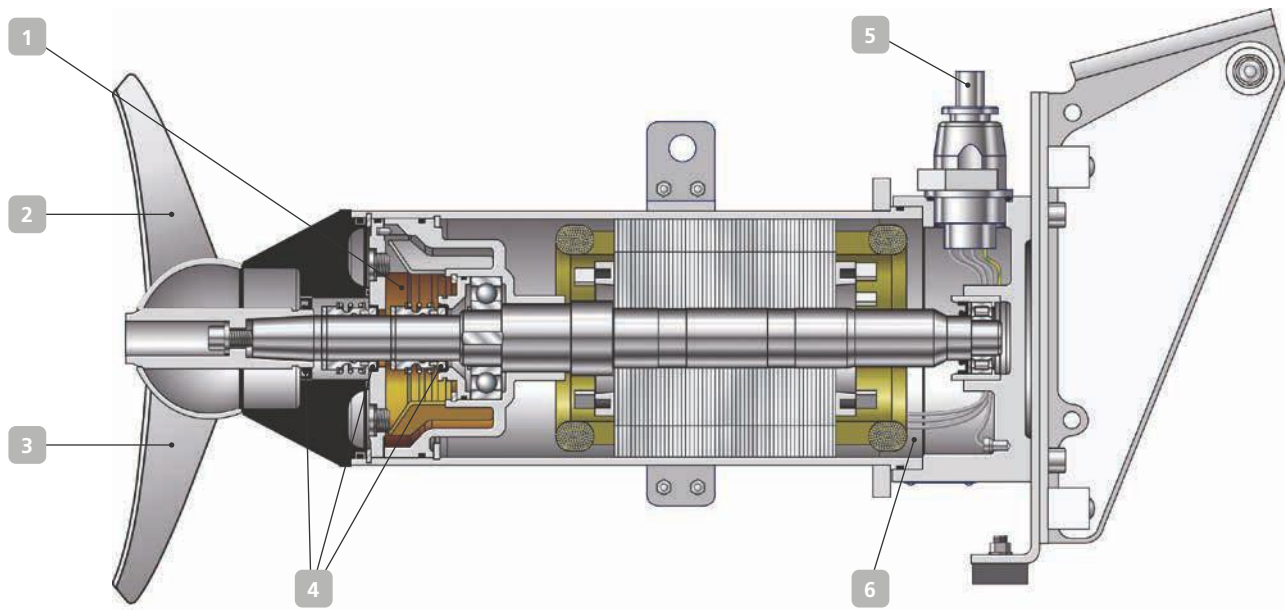

1 Environmentally friendly

The oil chamber is filled with ecologically acceptable white oil.

2 Powerful yet economical

Propeller generates maximum thrust at minimum power consumption.

3 Self-cleaning

ECB propeller (Ever Clean Blade)

4 Highly reliable

3-fold dynamic sealing system consisting of two (SiC/SiC) mechanical seals and a lip seal.

5 Perfectly protected

An absolutely water-tight, resin-embedded cable entry protects the motor against moisture. The plug-type connection enables straightforward replacement without special tools.

6 Everything under control

The motor is monitored by three temperature sensors and the moisture sensor.

7 16,000 operating hours without oil change*

*Oil change required every two years.

Technical data

Max. fluid temperature	max. 40 °C optional: 60 °C
Speed	475 to 1,400 1/min
Power	1.25 to 10 kW
Nom. propeller diameter	225 to 630 mm
Max. installation depth	max. 30 m
Explosion-proof to ATEX	
Optionally available with jet ring and frequency inverter	

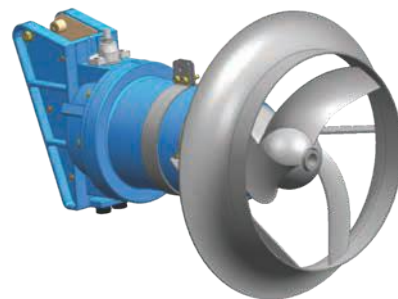

Amamix with jet ring



KSB SE & Co. KGaA
Johann-Klein-Straße 9
67227 Frankenthal (Germany)
www.ksb.com